



Velo

EN

Product & Training Manual

Corded Backpack Vacuum Cleaner



pacvac.com

Product & Training Manual

ENGLISH

Corded Backpack Vacuum Cleaner

Contents

English	10
General Safety Instructions	10
Product Specific Safety Instructions	11
Symbol Definitions	11
Specifications	12
Specifications - UK models	12
Design Registrations	12
Troubleshooting.....	13
Service Requirements	13
Operating Instructions	14
Safety and Maintenance Checks	16
Safe Disposal	16
Wear Right.....	17
Warranty	18
Spare Parts	19
Optional Extras.....	20
EC Declaration of Conformity	21

CAUTION Read this Product & Training Manual before using the machine and instruct operators if applicable.
RETAIN FOR FUTURE REFERENCE.

This manual applies to the Velo backpack vacuum cleaner.

General Safety Instructions

WARNING To reduce the risk of fire, electric shock or injury, read all instructions before using. When using an electrical appliance, basic precautions should always be followed.

1. This manual shall be considered an integral part of the machine and should be carefully looked after for subsequent reference.
2. **WARNING** This machine is not suitable for picking up hazardous dust.
3. **WARNING** Do not allow the power cord to come into contact with rotating brushes of floor tools.
4. **WARNING** Do not use this machine in wet conditions.
5. **CAUTION** This machine shall be stored and used indoors only.
6. Remove the machine from packaging and ensure it and all its accessories and attachments are present and in perfect condition. Contact the place of purchase immediately in the event of any discrepancies.
7. The electrical specifications of this machine are noted on the data plate which is located near the power switch. Ensure the specifications correspond to those of the mains power supply in your area. If the machine is without a data plate, contact the place of purchase immediately.
8. **WARNING** This machine is intended for the vacuuming of dry dust and/or small debris off dry carpeted or hard floor surfaces in indoor areas only.
9. **WARNING** Do not use the machine without the dust bag and filters in place.
10. Do not restrict the vacuum cleaner's airflow. Maintain the vacuum cleaner regularly so that all filters and openings are free of dust, lint, hair build-up or anything else which may affect airflow. Refer to the Safety and Maintenance Checks in this Product & Training Manual.
11. Regularly check the power cord for damage, such as cuts, abrasions, exposed wiring or aging. If the power cord or plug is damaged, the complete power cord must be replaced by your local Authorised Pacvac Service and Warranty Agent in order to avoid an electric shock. The power cord should only be replaced with a Pacvac Genuine Spare Part with the same specifications.
12. If the machine has been dropped, damaged, left outdoors or has been exposed to liquids, return it to your local Authorised Pacvac Service and Warranty Agent for a safety check.
13. Do not use the machine to pick up flammable or combustible liquids, such as petrol etc. and do not use in areas where they may be present.
14. Do not vacuum anything that is burning or smoking such as cigarettes or hot ashes.
15. Do not vacuum up hard or sharp objects such as glass, nails, screws etc.
16. Keep hair, loose clothing, fingers and all parts of the body away from moving parts and openings.
17. Keep the machine and power cord away from heated surfaces.
18. Do not unplug the machine while it is turned on. Turn the machine off, turn the power off at the power outlet then unplug by grasping the plug and pulling gently to unplug.
19. Do not handle the machine, power cord or plug with wet hands.
20. Unplug from power point when not in use, before servicing or before changing filters and attachments.
21. Do not pull or carry the machine by the power cord.
22. Do not close doors on the power cord and do not pull the cord around sharp edges or corners.
23. Store in an appropriate place after use to prevent tripping accidents.
24. This appliance is not intended for use by persons (including children) with reduced physical, sensory or mental capabilities, or lack of experience and knowledge, unless they have been given supervision or instruction concerning use of the machine by a person responsible for their safety. Children should be supervised to ensure that they do not play with this machine.
25. (Applicable in Europe only) This appliance can be used by children aged from 8 years and above and persons with reduced physical, sensory or mental capabilities or lack of experience and knowledge if they have been given supervision or instruction concerning use of the appliance in a safe way and understand the hazards involved. Children shall not play with the appliance. Cleaning and user maintenance shall not be made by children without supervision. Use only the manufacturer's recommended attachments and/or replacement parts.

Product Specific Safety Instructions

1. The following models have a "A"-weighted emission sound pressure level (at ear) of:
Velo - 65.3dB(A)
2. **WARNING** Only use the socket outlet on the machine for purposes specified within these instructions.
3. Part No. FLT001 - All purpose floor tool is intended for vacuuming dry dust and debris off floor surfaces.
4. Part No. ACC001 - Dusting brush is intended for vacuuming of dry dust from blinds and other delicate surfaces.
5. Part No. ACC002 - Crevice tool is intended for vacuuming of dry dust and debris from crevices.
6. Part No. ACC003 - Upholstery tool is intended for vacuuming of dry dust from upholstered surfaces.

IMPORTANT: The motor is equipped with a thermostat. If for any reason, the vacuum cleaner should over-heat, the thermostat will automatically turn the unit off. Should this occur, turn off the switch and unplug the vacuum cleaner from the electrical outlet and conduct safety and maintenance checks. Allow the cleaner to cool for approximately 30 minutes. To re-start, plug into a power point and switch back on.

Motor Thermostat

RETAIN THESE SAFETY INSTRUCTIONS FOR FUTURE USE.

Symbol Definitions

1. Attention!



2. Operator's Manual; Operating Instructions



Specifications

Model Name	Velo AU/NZ	Velo UK/EU
Model No.	01VE002VB	01VE002VB
Volts/Frequency	220-240V~ 50Hz 900W	220-240V~ 50Hz 850W
Motor	900W single-stage flow through	850W single-stage flow through
Max Suction Power	192W	192W
Noise Level (at ear)	65.3dB(A)	65.3dB(A)
Filtration	4 stage; H13 HEPA filter (pre-motor)*	4 stage; H13 HEPA filter (pre-motor)*
Volumetric Airflow (Max.)	28.2L/s	28.2L/s
Max Pressure	18.6kPa	18.6kPa
Capacity	2.5L	2.5L
Weight (excluding power cord assembly and hose)	3.9kg	3.9kg
Power Source	Mains, 18m power cord	Mains, 18m power cord
Vibration Level	≤2.5m/s ²	≤2.5m/s ²

Specifications - UK models

In accordance with EN 60335-2-69

Model Name	Velo
Model No.	01VE002VB
Sound pressure (LpA)	≤65.3dB(A)
Sound power (LwA)	<79±2dB(A)
Vibration level	≤2.5m/s ²

Design Registrations

EP Registered Design	001617051-0001
----------------------	----------------

*99.95% removal of particles <0.3micron

Technical specifications are subject to change without notice.

Troubleshooting

Caution: Always unplug the backpack before attempting to solve a problem or when servicing.

Problem	Cause	Solution
Backpack not working.	Power cord not firmly plugged into power point, short lead, or machine.	Check all plugs and sockets are firmly plugged in.
	Backpack shuts off due to high motor temperature.	Turn main switch off and unplug the backpack. Conduct safety and maintenance checks found in this Product and Training Manual or as per labelling on the machine. After 30 minutes (60 minutes for wispa) the backpack should be ready for use. If not contact the number below for your nearest Authorised Pacvac Service and Warranty Agent.
	Circuit breaker or RCD has tripped.	Check the machine is in good working order. If OK, reset circuit breaker or RCD. If circuit breaker or RCD trips again contact your nearest Authorised Pacvac Service and Warranty Agent.
Backpack has no/poor suction.	Hypercone™ dust bag full.	Remove, empty and clean Hypercone™ dust bag.
	Hypercone™ dust bag not installed correctly.	Remove and empty dust bag making sure the rubber edging is correctly fitted around the canister.
	Hose not installed correctly.	Reconnect hose and ensure correctly sealed.
	Blockages.	Remove hose, wand and floor tools; remove any blockages.
	Filters blocked.	Clean the Hypercone™ filter and external motor filter.

Service Requirements

Our products are designed and built to be functional and durable. For information on use and maintenance please read this Product & Training Manual thoroughly.

Should you require servicing contact your nearest Authorised Pacvac Service and Warranty Agent.

Operating Instructions

1. Wear the machine comfortably, adjust the harness if needed.
2. Stand upright, with the anti-static curved handpiece section parallel to the floor.
3. Always ensure that the cord is connected to the cord restraint, and secured by the hook, as shown on page 15 (Installing the cable).
4. Turn the machine on. The switch is located underneath the machine.
5. Hold the anti-static curved handpiece with one hand at a comfortable arm's length.
6. Move forward and away from the power point.
7. Use easy underarm swinging motion when detail cleaning and short dabs when spot cleaning, always standing upright.
8. Once the end of the power cord has been reached and work completed, return to the powerpoint along the cord line to switch the power off, and disconnect the power cord from the powerpoint.
9. If work is not completed and you need to move to another area, switch mains off, disconnect the power cord, move toward desired area, connect power cord to the nearest powerpoint and repeat steps 1 through 6.
10. If work is completed disconnect power cord from the power point and wind from the machine towards the end of the power cord to reduce likelihood of cable twists. In the process check for nicks, cuts, fractures, and knots.

Removing the cable

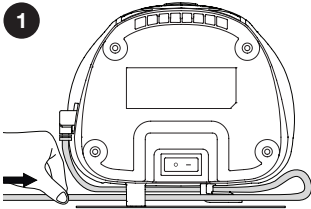

Push the cable forward to release the cord from the hook.

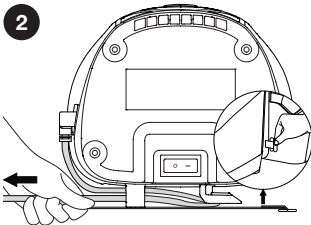

Once disengaged from the hook, pull the cable out by passing it through the slot.

You may have to push the waistband buckle aside to allow the cable to pass through.

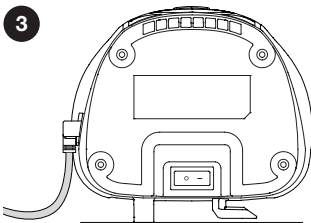

Pull the cable until it is clear from the machine.

Installing the cable

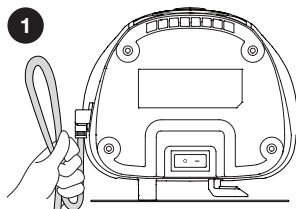

Hold the cable near the machine inlet and form a straight loop; approximately 15cm, as shown in the illustration.

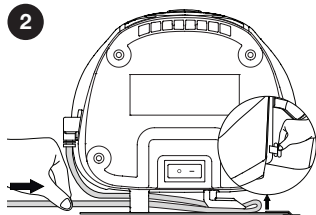

Feed the cable through the slot until it passes the hook. Secure onto the hook. Always ensure that this step is completed.

You may have to push the waistband buckle aside to allow the cable to pass through.

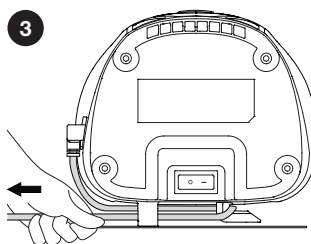

Once the cable is secured onto the hook, pull the cable away from the machine to ensure a tight fit, as shown in the illustration.

OPTIONAL HARNESS WAISTBAND

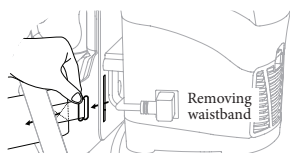

Removing waistband

Your machine comes fitted with the optional harness waistband. To remove it if you prefer to not use it, hold the metal clip located at the end of the waistband and pass through the slit at the back of the harness, then through the elasticated slot on the side of the harness.

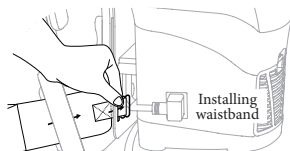

Installing waistband

To install the optional harness waistband, take one piece and pass through the elasticated slot on the side of the harness and feed the metal clip through the slit at the back of the harness, securing into place.

Safety and Maintenance Checks

DAILY

1. Replace the optional paper bag if needed. Remove, empty and clean the reusable dust bag.



2. Remove the filter and tap gently to clean.

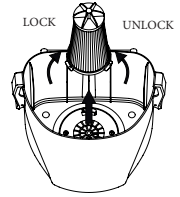

3. Check all power cords and ensure there are no cuts, abrasions or exposed wiring.

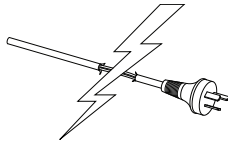

4. Check the floor tool, wand, handpiece and hose for any obstructions.

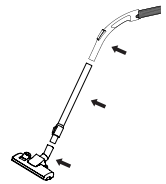

WEEKLY

Remove and clean the external motor filter.

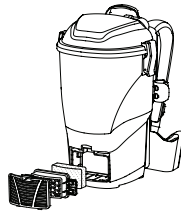

NOTE: Any other servicing should be performed by an Authorised Service & Warranty Agent. Please do not use if any damage is found.

Safe Disposal

Contact your local waste authority for information regarding available recycling and/or disposal options. Or contact Pacvac by emailing support@pacvac.com or phone +61 8 9479 1444 for the latest information.

Europe Only - When replacing old appliances with new ones, please check if the retailer is legally obligated to take back your old appliance for disposal.

Wear Right

In preparation of wearing the machine, follow these simple principles:

1

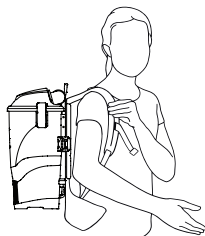

Wear comfortably

Loosen the shoulder straps and adjust the length, if required.

Lift the backpack by one shoulder strap and slide your free arm into the other strap.

2

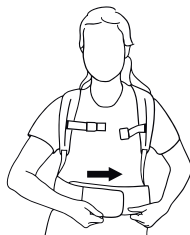

Tighten harness waistband

Wrap the harness waistband around your waist and adjust to ensure a comfortable fit.

This is an optional feature and you can detach the harness waistband from your machine if you prefer.

3



Adjust straps

Pull down on the shoulder straps until it feels comfortable.

Adjust the chest strap to the correct position for you, and click together to secure.

4

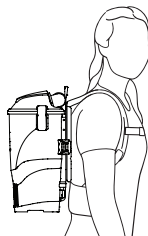

Correct posture

Make sure the machine is fitted comfortably to your frame.

IMPORTANT

If the backpack feels heavy or uncomfortable, it is likely you are not wearing it correctly. Contact Pacvac for further advice.

Warranty

Your Pacvac Pty Ltd (Pacvac) product has been manufactured to meet our highest quality standards. We urge you to take good care of your product and be sure to follow instructions carefully. This will provide you with the best possible performance and lifespan of the product.

The inclusion of the following paragraph is a requirement by Australian Law. It explains that consumers have rights by law regardless of any warranties provided or not by a manufacturer or supplier.

“Our goods come with guarantees that cannot be excluded under the Australian Consumer Law. You are entitled to a replacement or refund for a major failure and for compensation for any other reasonably foreseeable loss or damage. You are also entitled to have the goods repaired or replaced if the goods fail to be of acceptable quality and the failure does not amount to a major failure.”

In addition to the guarantees under Australian Consumer Law, Pacvac warrants all machines and their components against faulty material and / or workmanship for a period of two years from the date of purchase by the original consumer.

The following explains conditions and what to do in the event of a claim:

Pacvac will replace parts determined as faulty however this does not cover reasonable wear through normal use of any consumable parts, such as but not limited to, bags, filters, hoses, electrical leads, carbon brushes and floor tools etc.

Warranty does not cover any machine or component that has been altered, abused, neglected, modified, used with non-genuine Pacvac components or has not been used and maintained as indicated in this Product & Training Manual.

Warranty repairs can only be carried out by an Authorised Pacvac Distributor or Repairer. Visit our website for your nearest location. Warranty claims are limited to the original warranty period from the date of purchase. Warranty repairs and / or replacements do not extend the original warranty period.

All reasonable expenses associated with returning goods for a warranty claim are the consumer's responsibility.

Claims must be made within two years of the date of purchase and proof of purchase must be supplied with the claim.

To make a claim under warranty, take the product with proof of purchase to the place of purchase. If the place of purchase does not satisfactorily rectify the matter, please contact Pacvac.

Pacvac has the right to request pictures of warranty product failures or to request for those parts be returned to Pacvac's office in Western Australia.

The replacement of any part shall be at Pacvac's discretion.

Spare Parts

Quote these part numbers when ordering spare parts.

No.	Part Name	Part No.
1.	Dusting brush 32mm	ACC001
2.	Crevice tool 32mm	ACC002
3.	Upholstery tool 32mm	ACC003
4.	Wand tool holder	CLI007
5.	Reusable SMS cone dust bag 2.5L (grey)	DUB032
6.	Disposable paper dust bag 2.5L (10pk)	DUB034
7.	H13 HEPA Pre-motor cone filter 165mm	FIL030
8.	All purpose floor tool 285mm	FLT001
9.	Harness & waistband kit	HRT002
10.	Harness waistband	HAR008
11.	Screw fit hose 1.05m (antistatic handpiece)	HOA015
12.	Clear offset lid	LID005
13.	Aluminium extendable wand	WND007
14.	Power cord with vertical right angle C13 18m (plug type I)	PWC030
15.	Power cord with vertical right angle C13 18m (plug type G)	PWC031
16.	Power cord with vertical right angle C13 18m (plug type F)	PWC032

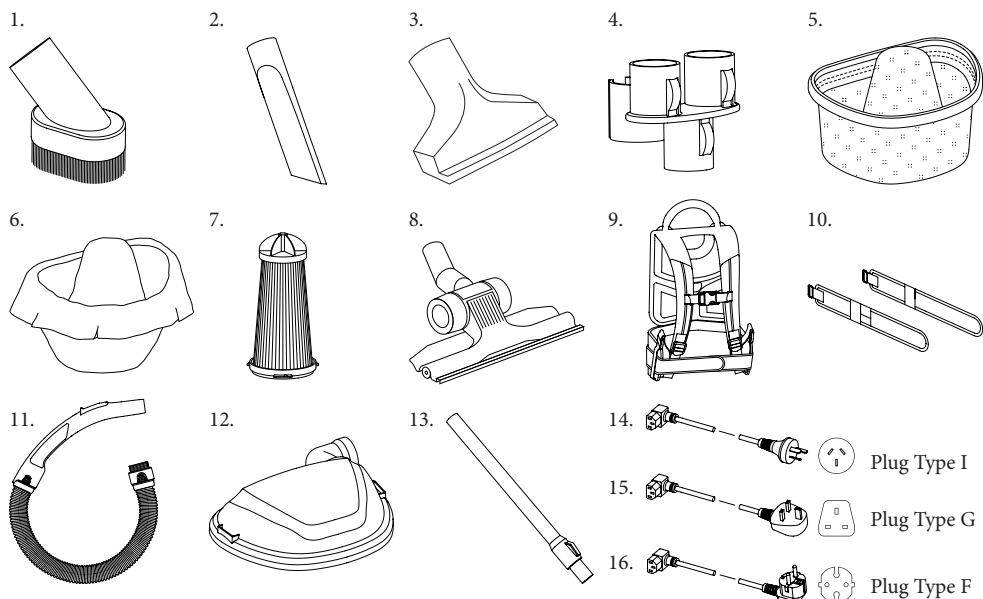

*Technical specifications, part numbers and parts designs are subject to change without notice.

Optional Extras

Quote these part numbers when ordering spare parts.

No.	Part Name	Part No.
1.	Pre-motor cone filter 165mm	FIL027
2.	Turbo head floor tool 280mm	FLT007
3.	Combination floor tool 260mm	FLT016
4.	Screw fit hose (antistatic handpiece) 1.2m (2.5L)	HOA018

1.

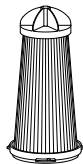

2.

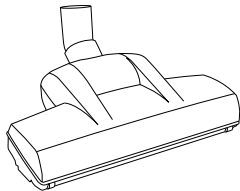

3.

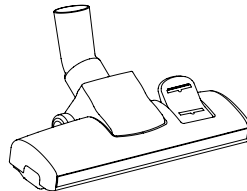

4.

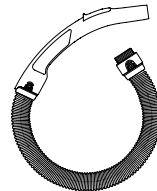

EC Declaration of Conformity

We hereby declare that the machines described below comply with the relevant basic safety and health requirements of the EU Directives, both in its basic design and construction as well as in the version put into circulation by us. This declaration shall cease to be valid if the machine is modified without our prior approval.

Product: Dry vacuum cleaner

Type: 01VE002VB

Relevant EU Directives

2006/42/EC

2014/30/EU

2011/65/EU

2009/125/EC

Applied harmonised standards

EN 55014-1: 2006+A1

EN 55014-2: 1997+A1

EN 60335-1

EN 60335-2-69

EN 61000-3-2: 2006+A1

EN 61000-3-3: 2008

Applied harmonised standards for UK

BS EN 60335-1:2012+A11+A13+A1+A14+A2

BS EN 60335-2-69:2012

BS EN 62233:2008

Applied national standards

-

Applied regulations

666/2013

The undersigned act on behalf and under the power of attorney of the company management.



D. Rothwell

Executive Director

Authorised Documentation Representative D. Rothwell.

Pacvac Pty Ltd

7 Mackay Street

Kewdale WA 6105

AUSTRALIA

Phone: +61 8 9479 1444

Fax: +61 8 9479 5444

April 2022

Online Manual

Visit helpdesk.pacvac.com or scan the QR code to access the online manual.



Revised: Feb 2024
MAN033-velo-manual-v04

Pacvac Pty Ltd
ABN: 60 709 396 593
7 Mackay Street, Kewdale WA 6105
AUSTRALIA

 +61 8 9479 1444

 support@pacvac.com

 pacvac.com

