

Numatic International Spare Parts

Model No: TTV678 & TRO650 CHASSIS / DRIVE MOTOR ASSEMBLY EXPLODED DRAWING

NB: FOR WIRING SEE DRAWING: WD-0359, DRW-15631, DRW-13416, DRW-14741

905585

**DRAWING: DRW-24936 ISS:A15
30/10/201**

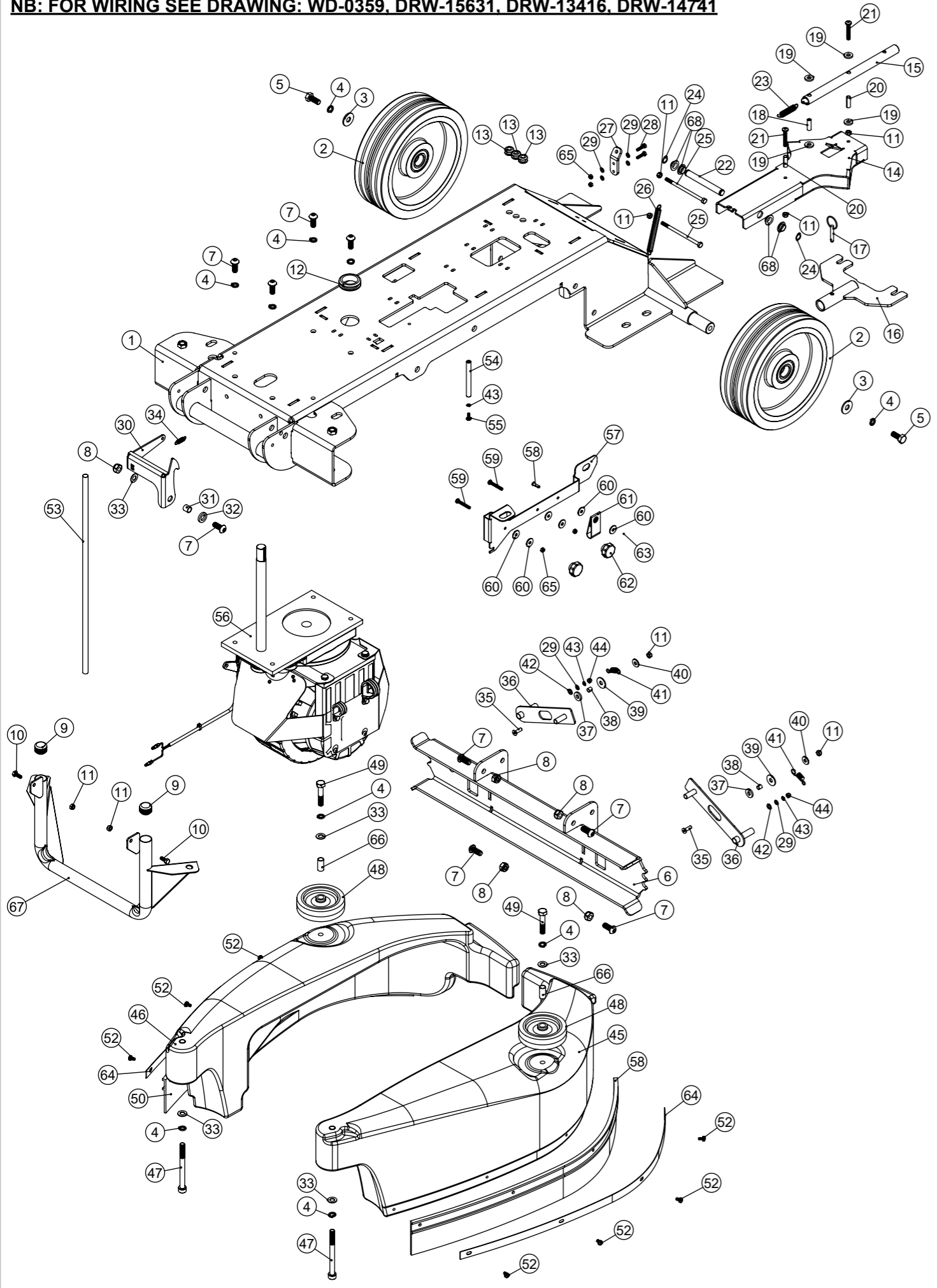

Numatic International Spare Parts

Model No: TTV678 & TRO650 CHASSIS / DRIVE MOTOR ASSEMBLY EXPLODED DRAWING

POS	ITEM NO.	DESCRIPTION	COMMENTS	QTY.
1	303784	CHASSIS WELDED ASSEMBLY (PAINTED GREY)		1
2	206939	254MM DIAMETER WHEEL		2
3	291124	M10 PENNY WASHER STAINLESS STEEL		2
4	219899	M10 SINGLE COIL STAINLESS STEEL WASHER		10
5	219909	M10 X 25MM LONG HEXAGONAL STAINLESS STEEL SCREW		2
6	901567	SIDE POD SLIDE PLATE ASSEMBLY ZINC PLATED	TTV678	1
	304457	TRO SIDE POD SLIDE PLATE ASSEMBLY ZINC PLATED	TRO650	1
7	219910	M10 X 25MM LONG SOCKET BUTTON HEAD STAINLESS STEEL SCREW		9
8	219897	M10 STAINLESS STEEL NYLON INSERT NUT		5
9	20637V	25.4MM TUBE END STOP		2
10	219719	M6 X 16MM LONG HEXAGONAL STAINLESS STEEL HEAD BOLT		2
11	219642	M6 STAINLESS STEEL NYLON INSERT NUT		8
12	208144	38MM GROMMET X 6MM PANEL THICKNESS		1
13	229025	STANDARD GROMMET		3
14	303797	TOP/BOTTOM LIFTING PLATE WELDED ASSEMBLY		1
15	303799	PIVOT TUBE WELDED ASSEMBLY		1
16	303795	QUICK RELEASE TUBE/PLATE WELDED ASSEMBLY		1
17	206953	DETENT PINS		1
18	206963	VERTICAL NYLON SPACER		1
19	206964	SLIDE NYLON SPACER		4
20	206954	SPIRO SPACER		2
21	902522	M6 X 40MM LONG SOCKET BUTTON HEAD STAINLESS STEEL BOLT		2
22	206965	PIVOT AXLE		1
23	206955	RETURN SPRING		1
24	905551	12MM EXTERNAL CIRCLIP ST/ST		2
25	905559	M6 X 110MM LONG HEXAGONAL HEAD BOLT ST/ST		2
26	20695V	SPRING		1
27	404195	REAR CABLE PLATE PAINTED ANTHRACITE GREY		1
28	291029	M5.20MM LG.HEX.SCREW S/S		2
29	219355	M5 FORM A STAINLESS STEEL WASHER		6
30	329849	BRUSH DECK FOOT PEDAL LATCH		1
31	303810	12.7MM DIAMETER X 18G X 12.5MM LONG STAINLESS STEEL TUBE		1
32	229346	SPACER		1
33	219903	M10 FORM A STAINLESS STEEL WASHER		5
34	208019	BRUSH PEDAL LATCH SPRING		1
35	908212	M6 X 20MM LONG COUNTERSUNK SOCKET SCREW STAINLESS STEEL		2
36	303813	SIDE POD ADJUSTER BRACKET WELDED ASSEMBLY	TTV678	2
	304458	TRO RH SIDE POD ADJUSTER BRACKET WELD ASSEMBLY	TRO650	1
	304459	TRO LH SIDE POD ADJUSTER BRACKET WELD ASSEMBLY	TRO650	1
37	219959	M8 PLASTIC WASHER		2
38	208475	8MM SPACER		2
39	219716	M8 FORM G STAINLESS STEEL WASHER		2
40	219647	M6 FORM G STAINLESS STEEL WASHER		2
41	208079	EXTENSION SPRING		2
42	219870	M6 FORM A WASHER STAINLESS STEEL		2
43	219016	M5 SHAKEPROOF WASHER		3
44	219645	M5 STAINLESS STEEL DOME NUT		2
45	N/A	LEFT HAND SIDE POD MOULDING		1
46	N/A	RIGHT HAND SIDE POD MOULDING		1
47	904944	M10 X 110 SOCKET CAP SCREW STAINLESS STEEL		2
48	-	100MM WHEEL (MODIFIED)		2
49	905557	M10 X 50MM LONG HEX HEAD BOLT ST/ST		2
50	206947	RIDE-ON SPLASH SKIRT		2
52	291135	M5 X 10MM LONG STAINLESS STEEL POZI PAN SEMS SCREW		8
53	208091	PB1.5MM X 500MM LONG / SEALED ENDS / BLACK POLYESTER BRAIDING		1
54	208804	87MM LONG ALUMINIUM SPACER		1
55	219740	M5 X 12MM LONG STAINLESS STEEL POZI PAN SCREW		1
56	N/A	VARIO DRIVE WHEEL ASSEMBLY	SEE DRW-24377	1
57	904918	POWER PLUG BRACKET		1
58	904922	CLEVIS PIN 3/16 x 5/8 STAINLESS STEEL		1
59	219661	M5 X 35MM LONG POZI PAN STAINLESS STEEL SCREW		2
60	291118	M5 STAINLESS STEEL WASHER 19MM OD		6
61	N/A	RETAINING STRAP		1
62	208455	TTB 1840 SQUEEGEE KNOB		2
63	904923	MINI R-CLIP STAINLESS STEEL		1
64	329843	VARIO SPLASH SKIRT FIXING STRIP		2
65	291035	M5 NYLON INSERT NUT (STAINLESS STEEL)		4
66	391224	1/2 INCH DIA X 18G S/S TUBE (0.026)		2
67	908759	BUMPER WELD ASSEMBLY (TRG) PAINTED SILVER		1
68	908803	IGUS BEARING (GFM-1315-06)		4

Numatic International Spare Parts

Model No: TTV678/300 & TRO650 BOTTOM TANK / PUMP / PEDAL ASSEMBLY EXPLODED DRAWING

NB: FOR WIRING SEE DRAWING: WD-0359, DRW-15631, DRW-13416, DRW-14741

Internal Code: 905579
 DRAWING: DRW-24896 ISS:A05
 PRO 16/10/2017

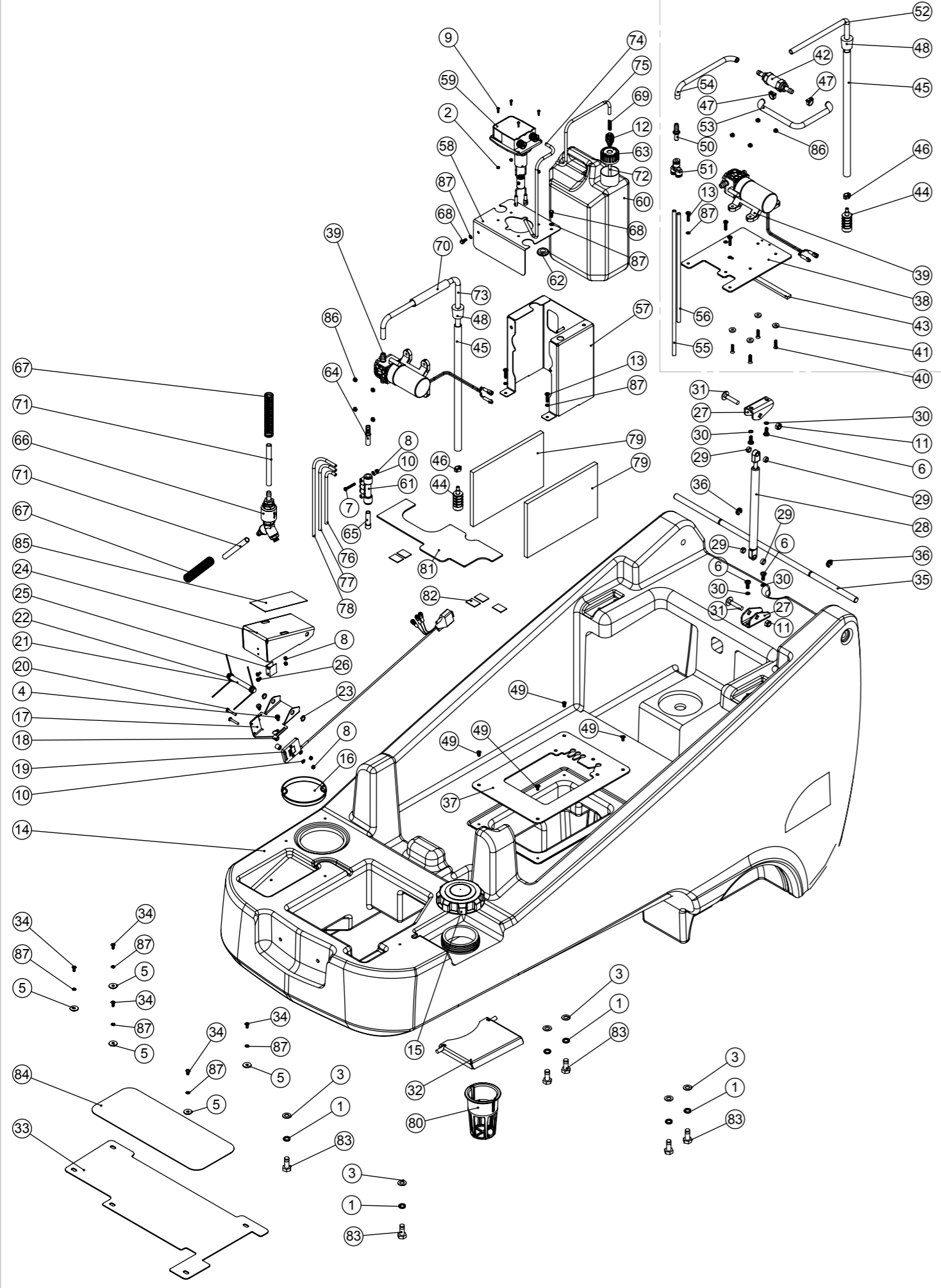

Numatic International Spare Parts

Model No: TTV678/300 & TRO650 BOTTOM TANK / PUMP / PEDAL ASSEMBLY EXPLODED DRAWING

ITEM	PART No:	DESCRIPTION	COMMENTS:	QTY.
1	219899	M10 SINGLE COIL STAINLESS STEEL WASHER		6
2	291154	M3 NYLON INSERT NUT STAINLESS STEEL	ITV678	4
3	219903	M10 FORM A STAINLESS STEEL WASHER		6
4	291135	M5 X 10MM LONG STAINLESS STEEL POZI PAN SEMS SCREW		2
5	291118	M5 STAINLESS STEEL WASHER 19MM OD		5
6	219646	M6 X 16MM LONG POZI PAN STAINLESS STEEL SCREW		4
7	219913	M4 X 30MM LONG POZI PAN STAINLESS STEEL SCREW	ITV678	1
8	219687	M4 STAINLESS STEEL NYLON INSERT NUT	ITV678	5
9	902534	M3 X 10MM LONG POZI PAN SCREW STAINLESS STEEL	ITV678	4
10	219688	M4 FORM A STAINLESS STEEL WASHER		3
11	219639	M8 STAINLESS STEEL NYLON INSERT NUT		2
12	208032	6MM BULKHEAD CONNECTOR	ITV678	1
13	219571	M5 X 20MM LONG POZI PAN STAINLESS STEEL SCREW	TRO650	5
14	237536	TRO BOTTOM TANK MOULDING		1
	237564	TRO650 BOTTOM TANK MOULDING (EP)	WITHOUT LOGO	1
15	904198	FILLER CAP RED	BLACK VERSION 208077	1
16	219452	100MM DIAMETER HOLE PLUG		1
17	329841	ACCELERATOR HINGE PLATE		1
18	219574	NYLON SPACER		2
19	206905	ACCELERATOR SENSOR		1
20	291165	M4 X 25MM LONG POZI SCREW STAINLESS STEEL		2
21	208046	CIRCLIP BAR		1
22	208047	TORSION SPRING (LEFT HAND)		2
23	905550	10MM EXTERNAL CIRCLIP ST/ST		2
24	329840	ACCELERATOR PEDAL COVER		1
25	404051	GILL SENSOR ACTIVATOR PLATE (PAINTED ANTHRACITE GREY)		1
26	219697	M4 X 8MM LONG POZI PAN STAINLESS STEEL SCREW		2
27	392455	GAS STRUT BRACKET - CARRIAGE BOLT		2
28	208042	GAS STRUT		1
29	291121	NYLON SPACER I/D 8.2MM X O/D 12MM X 5MM LG		4
30	291060	WASHER M6 SHAKEPROOF STAINLESS STEEL		4
31	291120	M8 X 40 CARRIAGE BOLT S/S		2
32	303822	FILLER CAP COVER WELDED ASSEMBLY		1
33	329839	FLOOR PLATE	ITV678 & TRO650 ON-BOARD CHARGER	1
	392269	ITV678 FLOOR PLATE	ITV678 & TRO650 CHARGERLESS	1
34	291004	M5 X 10MM LONG STAINLESS STEEL BUTTON HEAD SCREW		5
35	208071	TOP TANK PIVOT TUBE		1
36	208072	PLASTIC FIXING RING		2
37	304471	TRO NUTSERTED PUMP PLATE		1
38	392340	TRO WATER PUMP PLATE		1
39	323118	WATER PUMP & LEAD ASSEMBLY		2
40	905558	M5 X 20MM LONG POZI PAN COUNTERSUNK SCREW ST/ST	TRO650	4
41	219573	SCREW INSULATOR	TRO650	4
42	304484	NON RETURN VALVE ASSEMBLY	TRO650	1
43	212267	12MM WIDE 6MM THICK INSEAL (150mm)	TRO650	1
44	208360	WEIGHTED FILTER		2
45	208793	TRO CLEAN WATER PIPE SLEEVE		2
46	219149	O CLIP 9-11MM		2
47	208840	NYLON HOSE CLAMP 12.0MM-13.8MM		2
48	304491	PROCESSED 23MM-27MM CONICAL STOPPER		2
49	291008	M5 X 10MM LONG POZI PAN COUNTERSUNK STAINLESS STEEL SCREW		4
50	206796	BARBED CONNECTOR	TRO650	1
51	208851	8MM X 8MM EQUAL Y PIECE	TRO650	1
52	391497	CLEAR PVC HOSE CUT TO LENGTH (665mm)	TRO650	1
53	391494	SILICON TUBE 8MM I/D X 3.2MM WALL SECTION (CUT 370MM)	TRO650	1
54	391498	SILICON TUBE 8MM I/D X 3.2MM WALL SECTION (CUT 250MM)	TRO650	1
55	391504	800MM LONG X 6MM I/D X 8MM O/D FLEXIBLE NYLON TUBE	TRO650	1
56	391503	600MM LONG X 6MM I/D X 8MM O/D FLEXIBLE NYLON TUBE	TRO650	1
57	304508	NUTSERTED TTV678 PUMP HOUSING WELD STUDS ASSEMBLY PAINTED SILVER GREY	ITV678	1
58	404200	ITV678 PUMP HOUSING COVER PAINTED SILVER GREY	ITV678	1
59	321663	DETERGENT PUMP & SOLDERED LEAD ASSEMBLY	ITV678	1
60	208320	5 LITRE PLASTIC CONTAINER	ITV678	1
61	208031	3 WAY MANIFOLD (10MM DIAMETER INPUT / 6MM DIAMETER OUTPUT)	ITV678	1
62	219735	GROMMET	ITV678	1
63	303827	PROCESSED BLUE CAP	ITV678	1
64	208035	10MM X 8MM BARBED CONNECTOR	ITV678	1
65	208034	10MM BLANKING PLUG	ITV678	1
66	208118	NON RETURN VALVE ASSEMBLY	ITV678	1
67	219333	COMPRESSION SPRING	ITV678	2
69	219498	M5 X 12MM LONG STAINLESS STEEL HEX SCREW		2
69	208880	25MM COMPRESSION SPRING	ITV678	1
70	208094	PB10MM X 110MM LONG / SEALED ENDS / BLACK POLYESTER BRAIDING	ITV678	1
71	391513	SILICON TUBE 8MM I/D X 3.2MM WALL SECTION (CUT 110MM)	ITV678	2
72	391358	315MM LONG X 4MM I/D X 6MM O/D FLEXIBLE NYLON TUBE	ITV678	1
73	391514	CLEAR PVC HOSE CUT TO LENGTH (1200mm)	ITV678	1
74	391516	330MM LONG X 4MM I/D X 6MM O/D FLEXIBLE NYLON TUBE	ITV678	1
75	391516	330MM LONG X 4MM I/D X 6MM O/D FLEXIBLE NYLON TUBE	ITV678	1
76	391517	610MM LONG X 4MM I/D X 6MM O/D FLEXIBLE NYLON TUBE	ITV678	1
77	391518	720MM LONG X 4MM I/D X 6MM O/D FLEXIBLE NYLON TUBE	ITV678	1
78	391519	840MM LONG X 4MM I/D X 6MM O/D FLEXIBLE NYLON TUBE	ITV678	1
79	208645	FOAM BATTERY SPACER	ITV678	2
80	904197	BOTTOM TANK FILLING FILTER RED	GREY VERSION 208790	1
81	392463	ITV.678.3MM POLYPROPYLENE COVER	ITV678	1
82	280022	19MM X 27MM DOUBLE SIDED PAD	ITV678	5
83	291141	M10 X 25MM LG HEX HEAD SCREW STAINLESS STEEL C/W THREADLOCK		6
84	208998	ANTI-SLIP TREAD PAD (SELF ADHESIVE)		1
85	903855	ACCELERATOR GRIP PAD (RED)	BLACK VERSION 391222	1
86	291035	M5 NYLON INSERT NUT (STAINLESS STEEL)		8
87	291084	WASHER.M5.SHAKEPROOF.STAINLESS STEEL	TRO650	12

Numatic International Spare Parts

Model No: TTV678-300 CHARGER / CHARGER SPACER / BATTERIES ASSEMBLY EXPLODED DRAWING

Internal Code: 906732
 DRAWING: DRW-25880 ISS:A05
 PRO 15/09/2017

NB: FOR WIRING SEE DRAWING: WD-0359, DRW-15631, DRW-13416, DRW-14741

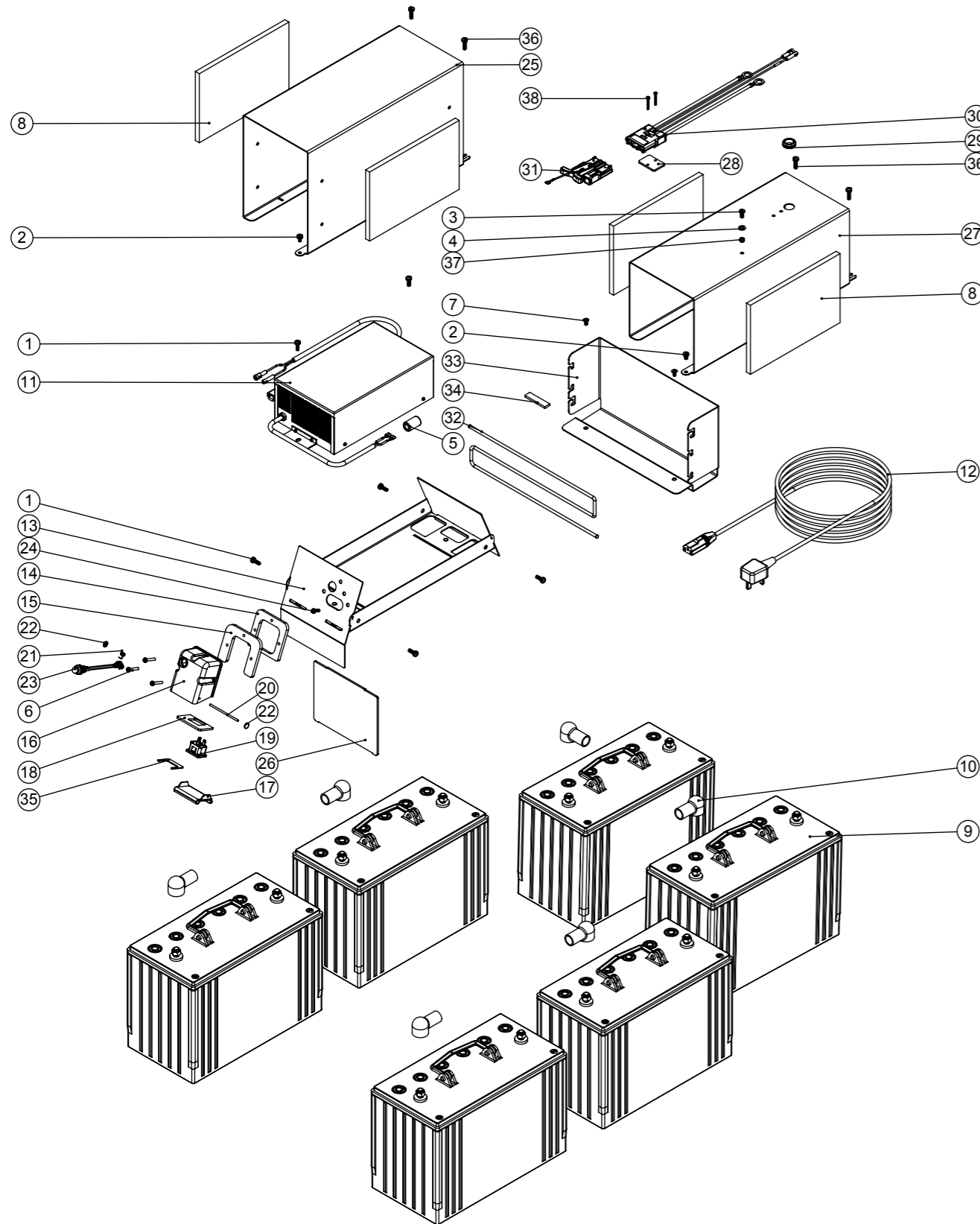

Numatic International Spare Parts

Model No: TTV678-300 CHARGER / CHARGER SPACER / BATTERIES ASSEMBLY EXPLODED DRAWING

ITEM NO.	PART NO:	DESCRIPTION	COMMENTS:	QTY.
1	291132	M5 X 16MM LONG STAINLESS STEEL POZI PAN SEMS SCREW		6
2	291135	M5 X 10MM LONG STAINLESS STEEL POZI PAN SEMS SCREW		2
3	219740	M5 X 12MM LONG STAINLESS STEEL POZI PAN SCREW	CHARGERLESS MACHINE	1
4	219493	M6 NYLON WASHER	CHARGERLESS MACHINE	1
5	230097	AXIAL FERRITE BEAD		1
6	291165	M4 X 25MM LONG POZI SCREW STAINLESS STEEL		3
7	291008	M5 X 10MM LONG POZI PAN COUNTERSUNK STAINLESS STEEL SCREW	CHARGERLESS MACHINE	2
8	208645	FOAM BATTERY SPACER		4
9	205112	100 AMP/HOUR REPLACEMENT BATTERY (C/W PACKING FOR 230138 BATTERY)		6
10	206861	RED PVC TERMINAL CAP		6
11	230189	220-240V MENTZER 30 AMP CHARGER (NO LIGHTS VERSION)	TTV678/300T	1
	230187	110-120V MENTZER 30 AMP CHARGER (NOLIGHTS VERSION)	TTV678/300T	1
	230143	220-240V MENTZER 35 AMP CHARGER	WITHOUT REMOTE INDICATOR	1
12	220386	UK TYPE CHARGING LEAD		1
	221079	EURO TYPE CHARGING LEAD		1
	220389	USA TYPE CHARGING LEAD		
13	404190	NUTSERTED TOP CHARGER TRAY WELD ASSEMBLY PAINTED SILVER GREY		1
14	329595	TOP SOCKET PLATE		1
15	392354	IEC CONNECTOR BOX SPACER PLATE		1
16	329355	SOCKET COVER MOULDING C/W LARGE MOULDED HOLE (WITH PROCESSED HOLES)	STANDARD MACHINE	1
	303629	SOCKET COVER MOULDING C/W LARGE MOULDED HOLE (WITH PROCESSED HOLES)	FLAME RETARDANT CSA SPEC	1
17	227781	FLAP MOULDING		1
18	329297	SOCKET MOUNTING PLATE		1
19	220391	3 PIN APPLIANCE SOCKET		1
20	390979	72MM LONG X 3MM DIAMETER STAINLESS STEEL BAR		1
21	219819	TORSION SPRING		1
22	219832	3MM DIAMETER STARLOCK		2
23	270193	NEON INDICATOR RED LENS 230V C/W LINK WIRES		1
	270195	NEON INDICATOR RED LENS 120V C/W LINK WIRES		1
24	219472	M4 X 16MM LONG POZI PAN SEMS SCREW		1
25	404186	CHARGER BOX		1
26	392346	CHARGER DEFLECTOR PLATE		1
27	304497	NUTSERTED CHARGER SPACER BOX PAINTED SILVER GREY	CHARGERLESS MACHINE	1
28	392370	3MM BLACK SBS CONNECTOR SPACER	CHARGERLESS MACHINE	1
29	219631	19MM GROMMET	CHARGERLESS MACHINE	1
30	323178	LOOM ASSEMBLY - 4 CIRCUIT - CHARGER/INHITIBT LEAD	CHARGERLESS MACHINE	1
31	323177	LOOM ASSEMBLY - 1 CIRCUIT - CHARGER/INHITIBT LEAD	CHARGERLESS MACHINE	1
32	208598	TTV678 POCKET BUNGEE CORD	CHARGERLESS MACHINE	1
33	304454	TTV678 POCKET PAINTED GREY - NUTSERTED	CHARGERLESS MACHINE	1
34	212262	50mm LONG -12MM X 4MM X 1500MM V6 OPEN CELL NATURAL SPONGE	CHARGERLESS MACHINE	1
35	901963	SECONDARY SPACER		1
36	291133	M5 X 20MM LONG STAINLESS STEEL POZI PAN SEMS SCREW		4
37	291035	M5 NYLON INSERT NUT (STAINLESS STEEL)		1
38	904052	M3 X 25MM LONG POZI PAN SCREW STAINLESS STEEL		2

Numatic International Spare Parts

Model No: TTV678/300 AND TRO650 TOP TANK / LIGHT / VAC POD & HOSE ASSEMBLY EXPLODED DRAWING

NB: FOR WIRING SEE DRAWING: WD-0359, DRW-15631, DRW-13416, DRW-14741

905584
DRAWING: DRW-24948 ISS:A21
21/01/2022

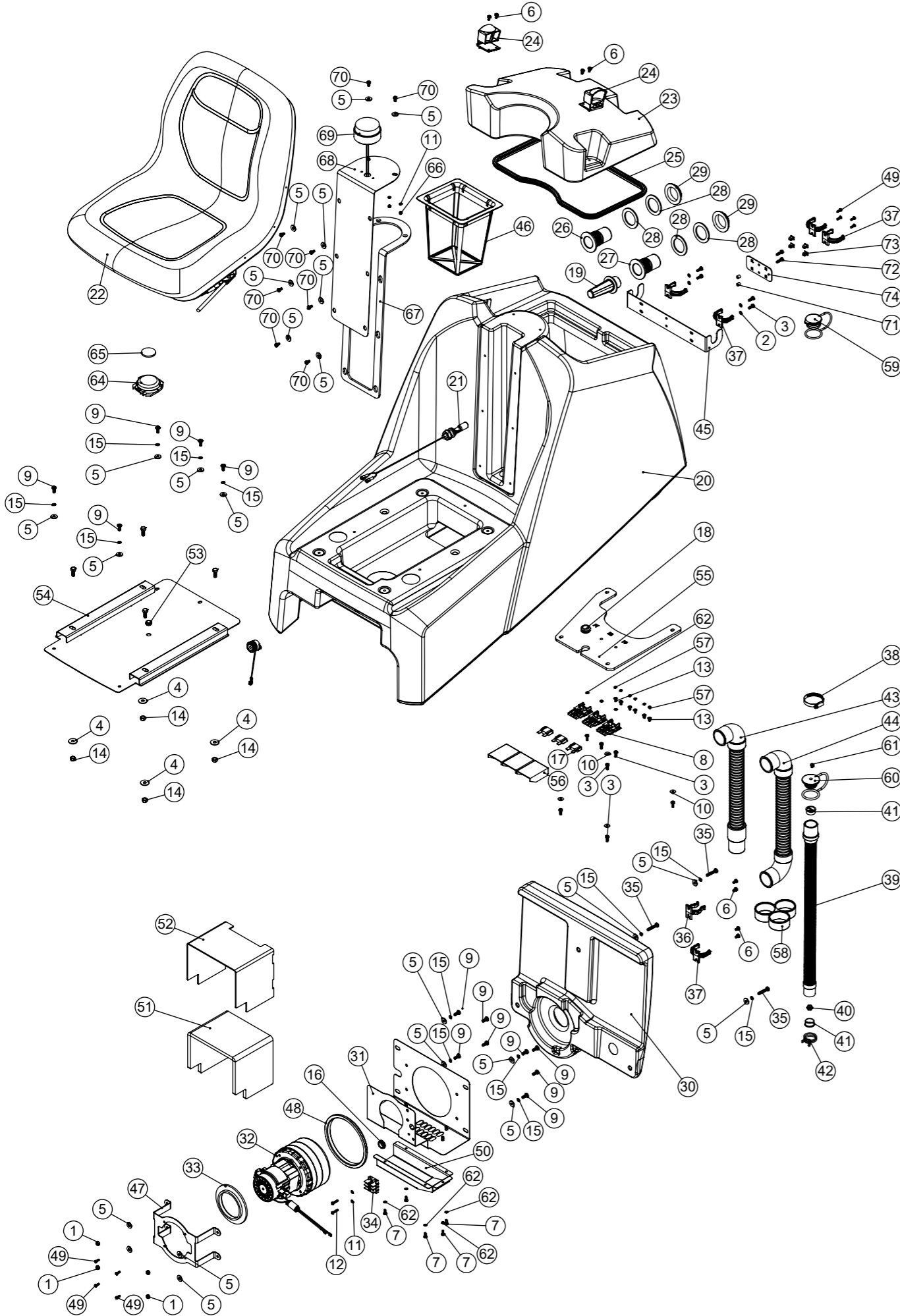

Numatic International Spare Parts

Model No: TTV678/300 AND TRO650 TOP TANK / LIGHT / VAC POD & HOSE ASSEMBLY EXPLODED DRAWING

ITEM	PART NO.	DESCRIPTION	COMMENTS	QTY.
1	219642	M6 STAINLESS STEEL NYLON INSERT HALF NUT		4
2	219355	M5 FORM A STAINLESS STEEL WASHER		4
3	291132	M5 X 16MM LONG STAINLESS STEEL POZI PAN SEMS SCREW		11
4	219716	M8 FORM G STAINLESS STEEL WASHER		4
5	219647	M6 FORM G STAINLESS STEEL WASHER		24
6	291135	M5 X 10MM LONG STAINLESS STEEL POZI PAN SEMS SCREW		8
7	219740	M5 X 12MM LONG STAINLESS STEEL POZI PAN SCREW		5
8	230102	FUSE HOLDER RATED AT 60 AMPS		3
9	219646	M6 X 16MM LONG POZI PAN STAINLESS STEEL SCREW		13
10	219644	M5 FORM G STAINLESS STEEL WASHER		4
11	219688	M4 FORM A STAINLESS STEEL WASHER		4
12	219686	M4 X 20MM LONG STAINLESS STEEL POZI PAN MACHINE SCREW		2
13	902896	M5 X 8 A2 S/ST PZ PAN HD M/SCREW DIN7985-Z		6
14	219639	M8 STAINLESS STEEL NYLON INSERT NUT		4
15	291060	WASHER M6 SHAKEPROOF STAINLESS STEEL		12
16	219631	19MM GROMMET		1
17	221047	40 AMP MAXI FUSE		3
18	208143	20MM GROMMET X 6MM PANEL THICKNESS		1
19	206265	TT/B 345 BARREL FILTER		1
20	237337	TTV TOP TANK MOULDING (GRAPHITE)	BLUE VERSION 229837	1
21	206944	FLOAT SWITCH		1
22	910522	MILSCO BACK SEAT XB 180		1
	208163	OPERATOR PRESANCE SEAT SWITCH	NOT SHOWN SEPARATELY	1
23	237336	TTV SEPARATOR MOULDING (GRAPHITE)	BLUE VERSION 229836	1
24	902919	CLIP MOULDING (RED)	GRAPHITE VERSION 229494	2
25	391209	1225MM LONG SEALING STRIP		1
26	237526	38MM RED DRAIN HOSE CONNECTOR		1
27	237018	38MM DRAIN HOSE CONNECTOR		1
28	219310	RUBBER WASHER		4
29	206116	BLACK NUT		2
30	237021	VARIO 3 STAGE BACK DOOR MOULDING		1
31	303886	NUTSERTED 3 STAGE MOTOR PLATE		1
32	303880	24V PERIPHERAL 3-STAGE VAC MOTOR & TERMINAL ASSEMBLY		1
33	202008	MOTOR CAP GASKET		1
34	220114	2 WAY TERMINAL BLOCK		1
35	219643	M6 X 35MM LONG STAINLESS STEEL POZI PAN SCREW		3
36	901916	28mm HOSE CLIP		1
37	237754	35-38MM HOSE CLIP		5
38	219919	32MM-50MM STAINLESS STEEL HOSE CLIP		1
39	213025	DUMP HOSE		1
40	904109	FLOAT MOULDING		1
41	904108	FLOAT STOP MOULDING		2
42	902133	SPRING WIRE CLAMP (YDNAC-Y8010356)		1
43	213059	SUCTION HOSE 1480MM X Ø38MM		1
44	213060	VAC HOSE 1060MM X Ø38MM		1
45	329904	RIDE-ON SQUEEGEE STORAGE BRACKET		1
46	206439	TANK FILTER		1
47	329987	MOTOR BRACKET		1
48	237032	>TPE< 3 STAGE MOTOR GASKET		1
49	219569	No8 X 1/2 INCH LONG POZI PAN STAINLESS STEEL PLASTITE SCREW		8
50	329989	SILENCER BOX		1
51	N/A	SILENCER FOAM		1
52	392019	SILENCER SHROUD		1
53	219680	GROMMET		1
54	304460	SEAT PLATE WELD ASSEMBLY PAINT SILVER GREY		1
55	304477	TRO NUTSERTED TOP TANK FUSE PLATE		1
56	208802	MAXI-FUSE HOLDER COVER		3
57	219861	M5 SINGLE COIL STAINLESS STEEL WASHER		6
58	237718	HOSE GUIDE		1
59	900901	RED HOSE CLOSURE (35MM-38MM)		1
	900903	HOSE CLOSURE REPLACEMENT KIT (25MM-38MM STRETCH HOSE)		1
60	903341	32MM HOSE CAP RED (C/W 8MM HOLE)		1
61	904403	BARBED RIVET BLACK		1
62	219016	M5 SHAKEPROOF WASHER		8
63	219717	M8 X 20MM LONG HEXAGONAL STAINLESS STEEL BOLT		4
64	N/A	OPERATOR PRESENCE SEAT SWITCH	REFERENCE	1
65	910520	SEAT SENSOR FOAM PAD		1
66	219687	M4 STAINLESS STEEL NYLON INSERT NUT		2
67	908117	BEACON BRACKET & COVER GASKET		1
68	908817	BEACON BRACKET & COVER (TRG) M/S		1
69	208867	FLASHING XENON BEACON X80 SERIES		1
70	291131	M5 X 12MM LONG STAINLESS STEEL POZI PAN SEMS SCREW		8
71	208475	8MM SPACER		2
72	291133	M5 X 20MM LONG STAINLESS STEEL POZI PAN SEMS SCREW		2
73	900986	NYLON GROMMET NUT (PLASTIC INSERT TO SUIT No 8 PLASTITE SCREW)		4
74	902516	HOSE CLIP BRACKET		1
75	915683	24V DC BUZZER & 6.3 X 0.8MM PUSH ON TERMINAL ASSEMBLY		1

Numatic International Spare Parts

Model No: TTV678 AND TRO650 FRONT MOULDING / LEVER & PANEL ASSEMBLY EXPLODED DRAWING

NB: FOR WIRING SEE DRAWING: WD-0359, DRW-15631, DRW-13416, DRW-14741

Internal Code: 905586
 DRAWING: DRW-24941 ISS:A11
 17/05/2019

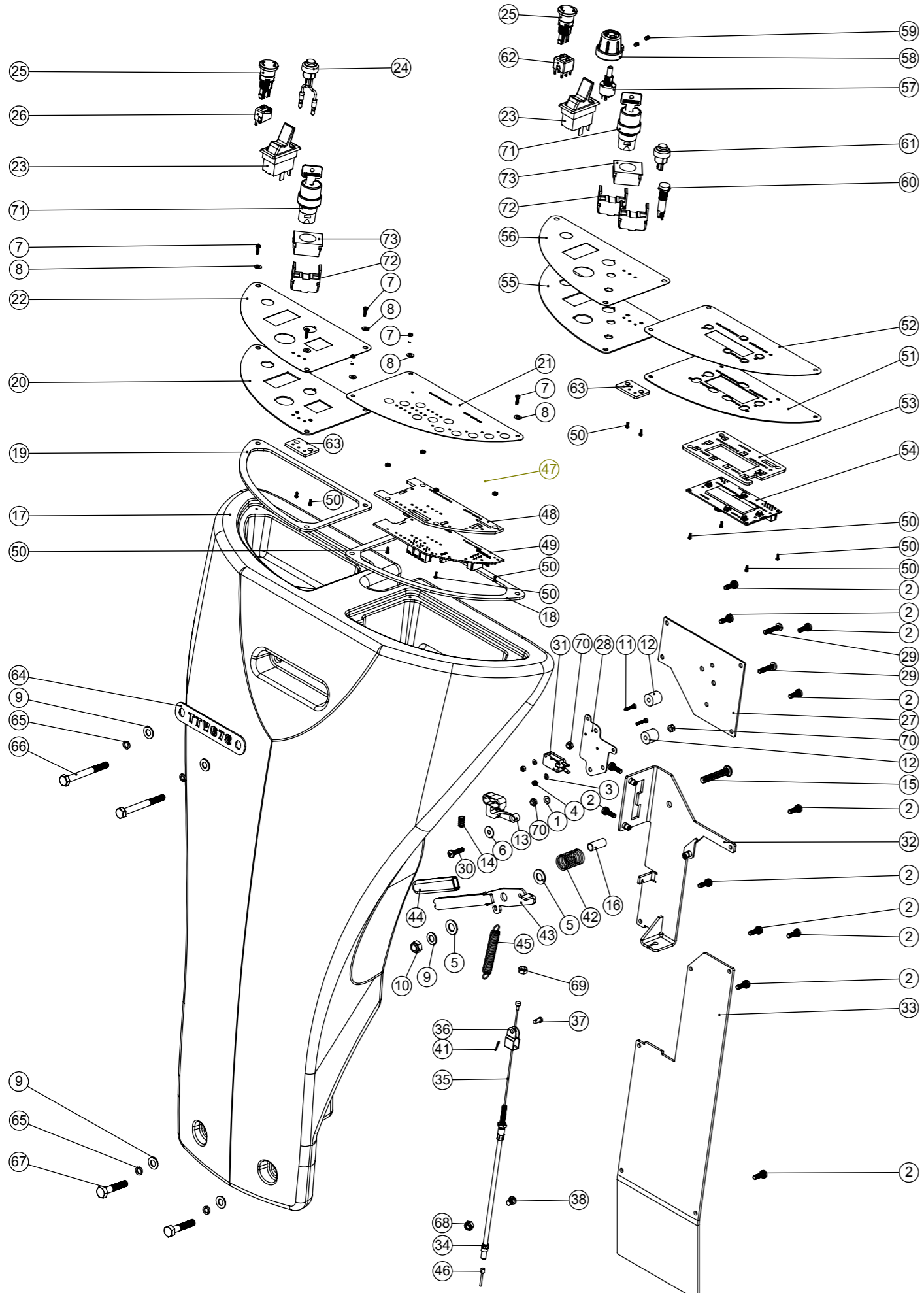

Numatic International Spare Parts

Model No: TTV678 AND TRO650 FRONT MOULDING / LEVER & PANEL ASSEMBLY EXPLODED DRAWING

ITEM	PART NO.	DESCRIPTION	COMMENTS	QTY.
1	219355	M5 FORM A STAINLESS STEEL WASHER		1
2	291132	M5 X 16MM LONG STAINLESS STEEL POZI PAN SEMS SCREW		13
3	219501	M3 FORM A STAINLESS STEEL WASHER		2
4	291154	M3 NYLON INSERT NUT STAINLESS STEEL		2
5	219903	M10 FORM A STAINLESS STEEL WASHER		2
6	219644	M5 FORM G STAINLESS STEEL WASHER		1
7	902534	M3 X 10MM LONG POZI PAN SCREW STAINLESS STEEL		6
8	219688	M4 FORM A STAINLESS STEEL WASHER		6
9	219578	M8 FORM A STAINLESS STEEL WASHER		5
10	219639	M8 STAINLESS STEEL NYLON INSERT NUT		1
11	219500	M3 X 16MM LONG STAINLESS STEEL SLOT SCREW		2
12	219587	15.39MM O/D X 5.16MM I/D X 15.88MM LONG NYLON SPACER		2
13	227587	CENTRE SWITCH OPERATING LEVER MOULDING		1
14	219804	SWITCH COMPRESSION SPRING		1
15	219822	M8 X 45MM LONG SOCKET BUTTON STAINLESS STEEL HEAD BOLT		1
16	391191	LEVER PIVOT SPACER (S/S 10MM O/D 8MM I/D X 24MM LONG)		1
17	237335	TTV STEERING COLUMN MOULDING (GRAPHITE)	BLUE VERSION 229858	1
18	208096	PCB GASKET		1
19	208097	KEY PANEL GASKET		1
	310062	PCB REPLACEMENT KIT (MK3) INCLUDES ITEMS: 5,48, 49, 50, 51	TTV678 BUILT AFTER 12/01/09	1
	310043	PCB REPLACEMENT KIT (MK2)	TTV678 BUILT AFTER 12/01/09	1
	310042	PCB REPLACEMENT KIT (MK1)	TTV678 BUILT BEFORE 12/01/09	1
20	907130	TTV678 CONTROL PANEL (NEW KEY) PAINTED GREY C/W CLINCH NUTS		1
	429116	KEY & E STOP PANEL (PAINTED SILVER GREY)	TTV678 BUILT BEFORE 12/01/02 ISSUE A07	1
21	208048	RIDE ON DISPLAY PANEL MEMBRANE (PEDAL VERSION)	TTV678	1
22	208833	KEY & E-STOP OVERLAY (CHARGER LEDS)	TTV678/300T ON-BOARD CHARGER	1
	208128	KEY & E-STOP OVERLAY STICKER	TTV678/400T, TTV678 CHARGERLESS	1
23	206933	FORWARD REVERSE EURO PADDLE SWITCH (8004K23N6V2)		2
24	321449	HORN SWITCH & SOLDERED LEAD ASSEMBLY	TTV678	1
25	206901	EMERGENCY STOP (A01MXB) 24MM DIAMETER BUTTON		2
26	208095	SWITCH BLOCK (SINGLE POLE / 2 POSITION) (A0151B)	TTV678	1
27	329830	LEVER SWITCH PLATE PAINTED SILVER		1
28	329831	LEVER SWITCH PLATE 2		1
29	219575	M5 X 25MM LONG POZI PAN STAINLESS STEEL SCREW		2
30	219571	M5 X 20MM LONG POZI PAN STAINLESS STEEL SCREW		1
31	229483	SNAP ACTION SWITCH		1
32	303790	LEVER PIVOT/SELECTOR PLATE WELDED ASSEMBLY		1
33	N/A	STEERING COLUMN COVER		1
34	206959	LIFTING CABLE ASSEMBLY	INCLUDES ITEMS: 36,37,38,39,42	1
35	208154	INNER CABLE		1
36	208157	CABLE U BRACKET		1
37	208158	CABLE U BRACKET PIN		1
38	208156	CABLE NIPL		1
41	208155	COTTER PIN		1
42	219592	COMPRESSION SPRING		1
43	303789	LEVER PLATE WELD ASSEMBLY		1
44	903870	LEVER HANDLE MOULDING RED	BLACK VERSION 206991	1
45	226093	EXTENSION SPRING		1
46	208451	RED INSULATED BOOTLACE FERRULE -18MM PIN	1 PER REQUIRED WHEN ORDERING ITEM 35	1
47	304274	METAL PCB SUPPORT PLATE PAINTED GREY C/W SELF CLINCH NUTS	TTV678	1
48	392151	PLASTIC PCB SUPPORT PLATE	TTV678	1
49	208518	USB CONTROL PANEL/PCB (MK3)	TTV678	1
50	905565	M2 X 6MM LONG POZI PAN SCREW ST/ST		12
51	304478	TRO CONTROL PANEL BACK PLATE PAINTED GREY C/W CLINCH NUTS	TRO650	1
52	208795	TRO DISPLAY PANEL MEMBRANE	TRO650	1
53	392044	DISPLAY PCB PLASTIC SPACER PLATE	TRO650	1
54	208791	TRO650 LCD DISPLAY WITHOUT DETERGENT		1
55	907131	TRO CONTROL PANEL (NEW KEY) PAINTED GREY C/W CLINCH NUTS	TRO650	1
56	208794	TRO KEY & EMERGENCY STOP OVERLAY	TRO650 ON-BOARD CHARGER	1
	208814	TRO KEY & EMERGENCY STOP OVERLAY NON CHARGER VERSION	TRO650 CHARGERLESS	1
57	270316	POTENTIOMETER TYPE Pe30 22k OHMS 20% 3W (WITH PANEL SEAL) (ROUND SHAFT WITH FLAT / NO SLOT IN SHAFT END)	TRO650	1
58	903498	SPEED ADJUSTMENT KNOB C/W INSERT (RED)	TRO650, GREY VERSION 329363	1
59	219744	M4 X 6MM LONG BLACKODISED GRUB SCREW	TRO650	2
60	270291	GREEN LED INDICATOR 2V C/W 2.2K RESISTOR	TRO650	1
61	229454	HANDLE SWITCH	TRO650	1
62	208458	SWITCH BLOCK (DOUBLE POLE / 2 POSITION) (A0152B)	TRO650	1
63	392360	TRO CHARGER PCB SPACER	TTV678/300T, TRO650 ON-BOARD CHARGER	2
64	901152	TTV678 BADGE	TTV678	1
	901153	TRO650 BADGE	TRO650	1
	901154	TTB3226 BADGE (NACE)	TTB3226	1
65	219898	M8 SINGLE COIL STAINLESS STEEL WASHER		4
66	291123	M8 X 75 LONG HEX HEAD BOLT STAINLESS STEEL		2
67	291112	M8 X 40 LONG HEX BOLT STAINLESS STEEL		2
68	219853	OBSOLETE PART - REPLACED BY 219642 - M6 NYLOC HALF NUT (STAINLESS STEEL)		1
69	219642	M6 STAINLESS STEEL NYLON INSERT HALF NUT		1
70	291035	M5 NYLON INSERT NUT (STAINLESS STEEL)		3
71	907149	KEY SWITCH SELECTOR (020SCA1)	907208 SPARE KEYS	2
72	907151	TERMINAL BLOCK N.O. (020E10)		3
73	907150	FIXING ADAPTER (020G)		2
74	208475	8MM SPACER		2
75	291133	M5 X 20MM LONG STAINLESS STEEL POZI PAN SEMS SCREW		2
76	900986	NYLON GROMMET NUT (PLASTIC INSERT TO SUIT No 8 PLASTITE SCREW)		4
77	219569	No8 X 1/2 INCH LONG POZI PAN STAINLESS STEEL PLASTITE SCREW		4
78	237754	35-38MM HOSE CLIP		2
79	902516	HOSE CLIP BRACKET		1
80	915683	24V DC BUZZER & 6.3 X 0.8MM PUSH ON TERMINAL ASSEMBLY		1

Numatic International Spare Parts

Model No: TTV678 & TRO650 STEERING COLUMN ASSEMBLY
EXPLODED DRAWING

Internal Code: 905587
PRO DRAWING: DRW-24947 ISS:A14
24/08/2022

NB: FOR WIRING SEE DRAWING: WD-0359, DRW-15631, DRW-13416, DRW-14741

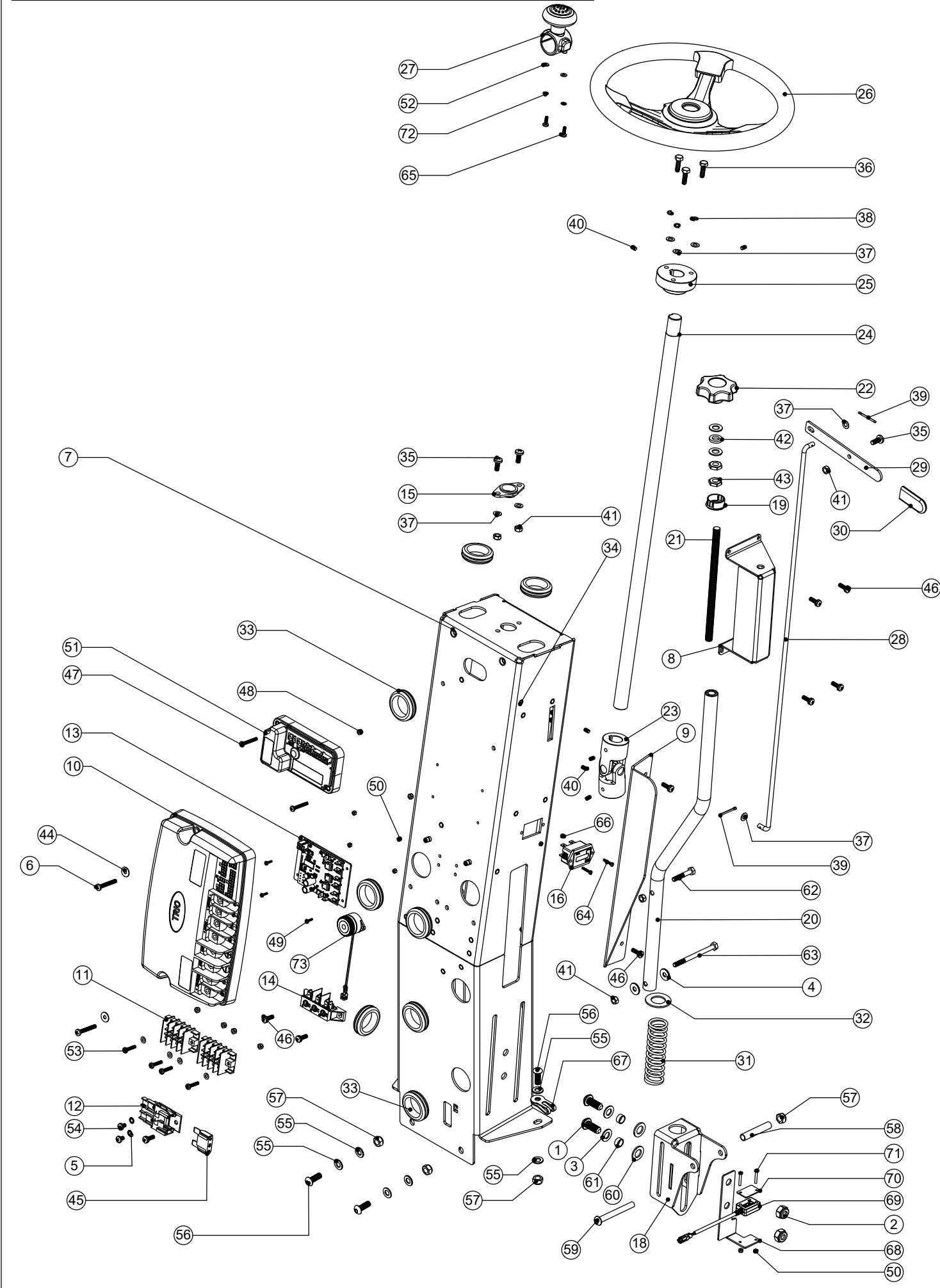

Numatic International Spare Parts

Model No: TTV678 & TRO650 STEERING COLUMN ASSEMBLY
EXPLODED DRAWING

ITEM:	PART No:	Description	QTY.
1	219910	M10 X 25MM LONG SOCKET BUTTON HEAD STAINLESS STEEL SCREW	2
2	219897	M10 STAINLESS STEEL NYLON INSERT NUT	2
3	219903	M10 FORM A STAINLESS STEEL WASHER	4
4	219647	M6 FORM G STAINLESS STEEL WASHER	2
5	219016	M5 SHAKEPROOF WASHER	2
6	219661	M5 X 35MM LONG POZI PAN STAINLESS STEEL SCREW	TTV678 2
7	303786	STEERING COLUMN WELDED ASSEMBLY (MANUAL VERSION) (PAINTED SILVER GREY)	1
8	329863	BRUSH PRESSURE ADJUSTMENT BRACKET	1
9	329888	STEERING COLUMN SPLASH GAURD	1
10	208169	PG CONTROLLER (Trio+HD 100) (MK2)	TTV678 1
11	221095	TERMINAL BLOCK (4 POLE X 6 WAY/TERMINALS)	TRO650-ONE BLOCK ONLY 2
12	230102	FUSE HOLDER RATED AT 60 AMPS	TTV678 1
13	N/A	DC DRIVE PCB	TRO650 1
14	206788	TERMINAL BLOCK	TRO650 1
15	208110	IGUS (R) 2 BOLT PLAIN BEARING 20MM I/D	1
16	208178	HOURS METER	TTV678 1
	392355	TRO HOURS METER BLANKING PLATE	TRO650 1
18	303819	RIDE-ON BRUSH PRESSURE ADJUSTMENT SLIDE	1
19	208021	19MM (3/4 INCH) SNAP BUSHING	1
20	303817	BRUSH PRESSURE ADJUSTMENT TUBE WELD ASSEMBLY	1
21	219969	M10 X 1.5MM X 190MM LONG S/S THREADED BAR	1
22	903281	M10 LOBE KNOB (RED)	BLACK VERSION 208354 1
23	N/A	UNIVERSAL JOINT	1
24	206940	STEERING SHAFT	1
25	206960	RIDE-ON STEERING WHEEL ADAPTOR	1
26	206961	300MM STEERING WHEEL C/W CENTRE CAP	1
27	208104	STEERING WHEEL KNOB	1
28	391195	PEDAL LATCH RELEASE ROD	1
29	329850	RELEASE HANDLE	1
30	904191	50MM LONG DIP MOULDED HANDLE COVER (RED)	BLACK VERSION 391226 1
31	208016	MANUAL BRUSH DECK ADJUSTMENT SPRING	1
32	291162	M20 FORM B STAINLESS STEEL WASHER	1
33	208029	GROMMET (32MM I/D)	8
34	219558	M5 STAINLESS STEEL NUTSERT	27
35	219646	M6 X 16MM LONG POZI PAN STAINLESS STEEL SCREW	3
36	219976	M6 X 20MM LONG HEXANGONAL HEAD SET SCREW	3
37	219560	M6 FORM B STAINLESS STEEL WASHER	7
38	219549	M6 SINGLE COIL WASHER	3
39	208030	COTTER PIN (2.4MM X 38.1MM)	2
40	219784	M5 X 8MM LONG BLACKODISED GRUB SCREW	6
41	219983	M6 NYLOC STAINLESS STEEL FULL NUT	5
42	219964	NYLON WASHER (18MM O/D X 10.4MM I/D X 3MM THICK)	1
43	219951	A4 (STAINLESS STEEL) M10 HEX LOCK NUT (HALF NUT)	2
44	219644	M5 FORM G STAINLESS STEEL WASHER	2
45	221091	20 AMP MAXI FUSE	TTV678 1
46	291132	M5 X 16MM LONG STAINLESS STEEL POZI PAN SEMS SCREW	9
47	219913	M4 X 30MM LONG POZI PAN STAINLESS STEEL SCREW	TRO650 2
48	219687	M4 STAINLESS STEEL NYLON INSERT NUT	TRO650 6
49	902534	M3 X 10MM LONG POZI PAN SCREW STAINLESS STEEL	TRO650 4
50	291154	M3 NYLON INSERT NUT STAINLESS STEEL	6
51	330179	PROGRAMMED 70A MOTOR CONTROLLER (TRO650)	TRO650 1
52	219688	M4 FORM A STAINLESS STEEL WASHER	6
53	219686	M4 X 20MM LONG STAINLESS STEEL POZI PAN MACHINE SCREW	4
54	902896	M5 X 8 A2 S/ST PZ PAN HD M/SCREW DIN7985-Z	2
55	219578	M8 FORM A STAINLESS STEEL WASHER	8
56	291064	M8 X 22MM LONG SOCKET BOLT STAINLESS STEEL	4
57	219639	M8 STAINLESS STEEL NYLON INSERT NUT	5
58	391199	54MM LONG X 10MM DIAMETER STAINLESS STEEL TUBE	1
59	291142	M8 X 70MM LG SOCKET BUTTON HEAD SCREW STAINLESS STEEL	1
60	219911	PLASTIC WASHER	2
61	303812	12.7MM DIAMETER X 18G X 5.5MM LONG STAINLESS STEEL TUBE	2
62	291127	M6 X 35 LONG HEX BOLT STAINLESS STEEL	1
63	219915	M6 X 80MM LONG STAINLESS STEEL HEXAGONAL HEAD BOLT	1
64	219500	M3 X 16MM LONG STAINLESS STEEL SLOT SCREW	TTV678 2
65	219890	M4 X 12MM LONG POZI PAN STAINLESS STEEL SCREW	TRO650 2
66	219502	M3 STAINLESS STEEL FULL NUT	TTV678 2
67	904962	CABLE CLAMP M8x65 (PP)	1
68	907245	REED SWITCH COLUMN BRACKET	1
69	904501	REED SWITCH ASSEMBLY	1
70	906617	REED SWITCH WASHER PLATE	1
71	291155	M3 X 20MM LONG POZI PAN SCREW STAINLESS STEEL	2
72	291145	M4 SHAKEPROOF WASHER STAINLESS STEEL	2
73	915683	24V DC BUZZER & 6.3 X 0.8MM PUSH ON TERMINAL ASSEMBLY	1

Numatic International Spare Parts

Internal Code: 905582
 DRAWING: DRW-24931 ISS:A14
 21/03/2018

Model No: TTV678 BRUSH DECK / LIFTING LINK / CHUCK ASSEMBLY EXPLODED DRAWING

NB: FOR WIRING SEE DRAWING: WD-0359, DRW-15631

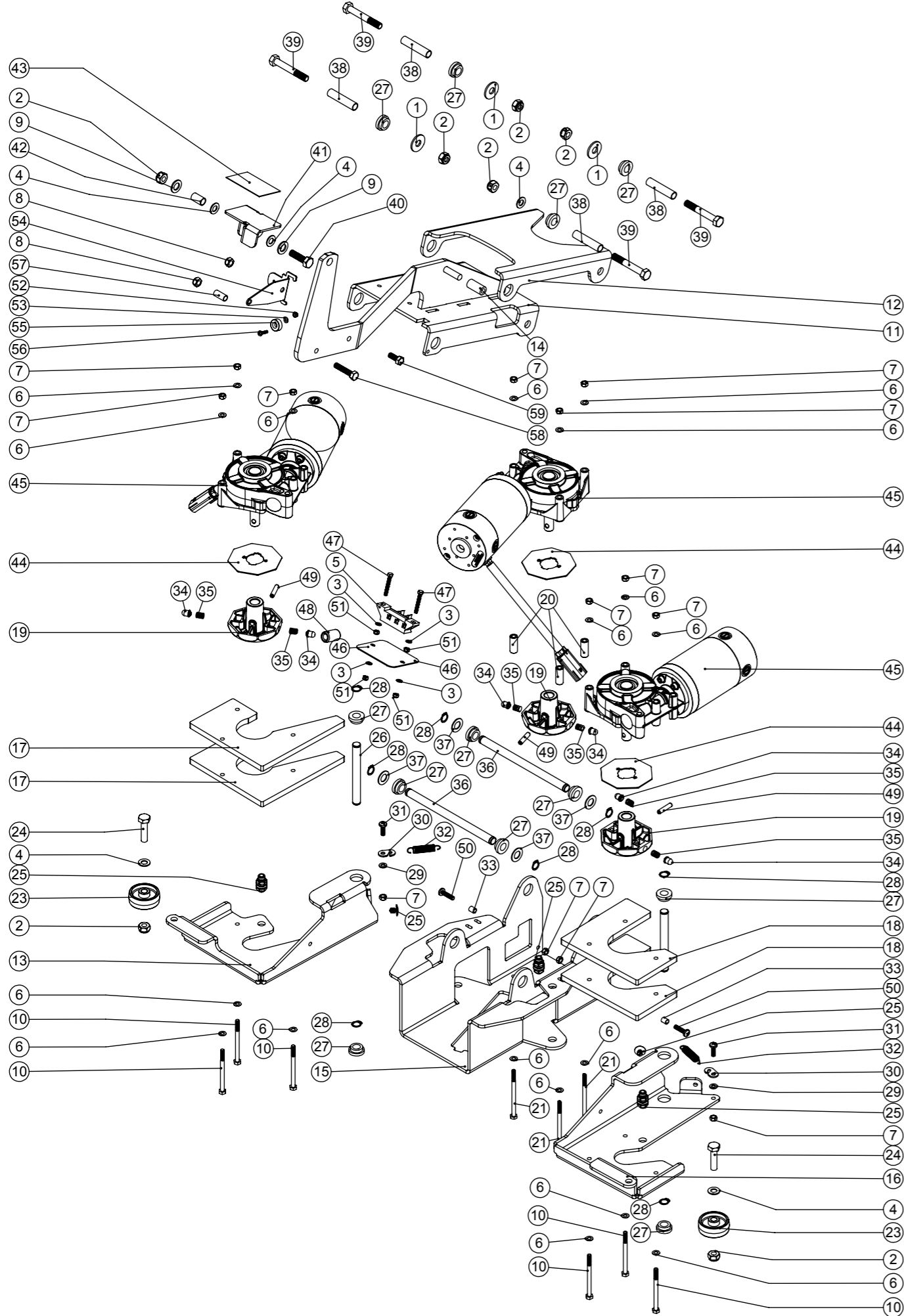

Numatic International Spare Parts

Model No: TTV678 BRUSH DECK / LIFTING LINK / CHUCK ASSEMBLY EXPLODED DRAWING

ITEM	PART NO.	DESCRIPTION	COMMENTS	QTY.
1	291124	M10 PENNY WASHER STAINLESS STEEL		3
2	219897	M10 STAINLESS STEEL NYLON INSERT NUT		7
3	219355	M5 FORM A STAINLESS STEEL WASHER	MODELS BUILT BEFORE 03/2014	4
4	219903	M10 FORM A STAINLESS STEEL WASHER		5
5	206788	TERMINAL BLOCK	MODELS BUILT BEFORE 03/2014	1
6	219560	M6 FORM B STAINLESS STEEL WASHER		18
7	219983	M6 NYLOC STAINLESS STEEL FULL NUT		13
8	219639	M8 STAINLESS STEEL NYLON INSERT NUT		2
9	219911	PLASTIC WASHER		2
10	219915	M6 X 80MM LONG STAINLESS STEEL HEXAGONAL HEAD BOLT		6
11	404044	BRUSH DECK PEDAL ARM WELDED ASSEMBLY - PAINTED SILVER GREY		1
12	404045	BRUSH DECK REAR LINK - PAINTED SILVER GREY		1
13	303803	WELDED BRUSH DECK RIGHT PIVOT PAINTED SILVER GREY		1
14	391211	SILICON TUBE 30MM LONG X 8MM I/D X 3.2MM WALL SECTION		1
15	329816	BRUSH DECK CENTRE PIVOT PAINTED SILVER GREY		1
16	303802	WELDED BRUSH DECK LEFT PIVOT PAINTED SILVER GREY		1
17	404037	RIDE-ON RH BRUSH DECK WEIGHT PAINTED SILVER GREY		2
18	404036	LEFTHAND BRUSH DECK WEIGHT (PAINTED SILVER GREY)		2
19	206966	CHUCK CASTING	SPARE PART: 303809 INCLUDING: 22,42,43,54,59	3
20	206851	MOTOR MOUNTING SPACER		3
21	291021	M6 X 90MM LONG STAINLESS STEEL HEXAGONAL HEAD BOLT		3
25	208024	PUSH IN BARBED FASTENER		2
23	206712	50MM DIAMETER BLACK WHEEL		2
24	903430	M10 X 40MM LONG HEXAGONAL STAINLESS STEEL SCREW		2
25	208032	6MM BULKHEAD CONNECTOR		3
26	206981	BRUSH DECK PIVOT PIN		2
27	208058	SHOULDERED BUSH - Ø12.9MM I/D		12
28	905563	13MM EXTERNAL CIRCLIP ST/ST		8
29	219493	M6 NYLON WASHER		2
30	329920	BRUSH DECK SPRING PIVOT BRACKET		2
31	219701	M6 X 20MM LONG POZI PAN STAINLESS STEEL SCREW		2
32	208050	BRUSH DECK ROTATION SPRING		2
33	219843	6MM I/D X 9.5MM LONG SPIROL SPACER (STAINLESS STEEL)		2
34	208135	CHUCK DOME		6
35	206957	DRIVE SYSTEM SPRING		6
36	206980	PIVOT TUBE		2
37	219302	M12 FORM B STAINLESS STEEL WASHER		4
38	391194	PIVOT TUBE A		4
39	904945	M10 X 70MM LONG HEX BOLT STAINLESS STEEL		4
40	219895	M10 X 35MM LONG HEXAGONAL STAINLESS STEEL SCREW		1
41	329807	FOOT PEDAL HINGE BRACKET		1
42	303811	12.7MM DIAMETER X 18G X 20MM LONG STAINLESS STEEL TUBE		1
43	904204	FOOT PEDAL GRIP PAD RED	BLACK VERSION 391221	1
44	392331	OCTO CHUCK PLASTIC COVER		3
45	205263	24V DC BRUSH DRIVE PM90 MOTOR/GEARBOX ASSEMBLY (14:1 RATIO) C/W WATERPROOF CONNECTOR		3
46	329922	BRUSH DECK TERMINAL SPLASH GAURD	MODELS BUILT BEFORE 03/2014	1
47	905554	M5 X 35MM LONG HEXAGONAL HEAD SCREW ST/ST	MODELS BUILT BEFORE 03/2014	2
48	230097	AXIAL FERRITE BEAD 17.5 X 9.5 X 28.5 (REF 742 700 9)	MODELS BUILT BEFORE 03/2014	1
49	291079	6MM X 30MM STAINLESS STEEL ROLL PIN		3
50	902232	M6 X 25MM LONG POZI PAN SCREW STAINLESS STEEL		2
51	291035	M5 NYLON INSERT NUT (STAINLESS STEEL)		4
52	219687	M4 STAINLESS STEEL NYLON INSERT NUT		1
53	219688	M4 FORM A STAINLESS STEEL WASHER		1
54	907246	MAGNET PEDAL ARM BRACKET		1
55	208382	MAGNET(19MM O/D)		1
56	219862	M4 X 16MM LONG POZI PAN STAINLESS STEEL SCREW		1
57	906651	SPACER (S/S 10MM O/D 8MM I/D X 22MM LONG)		1
58	291112	M8 X 40 LONG HEX BOLT STAINLESS STEEL		1
59	219717	M8 X 20MM LONG HEXAGONAL STAINLESS STEEL BOLT		1

Numatic International Spare Parts

Model No: TTV678 & TRO650 MOTOR WHEEL GEARBOX ASSEMBLY

Internal Code: 234605
PRO DRAWING: EXP-1033 ISS:A05

NB: FOR WIRING SEE DRAWING: WD-0359, DRW- 15631, DRW-13416, DRW-14741

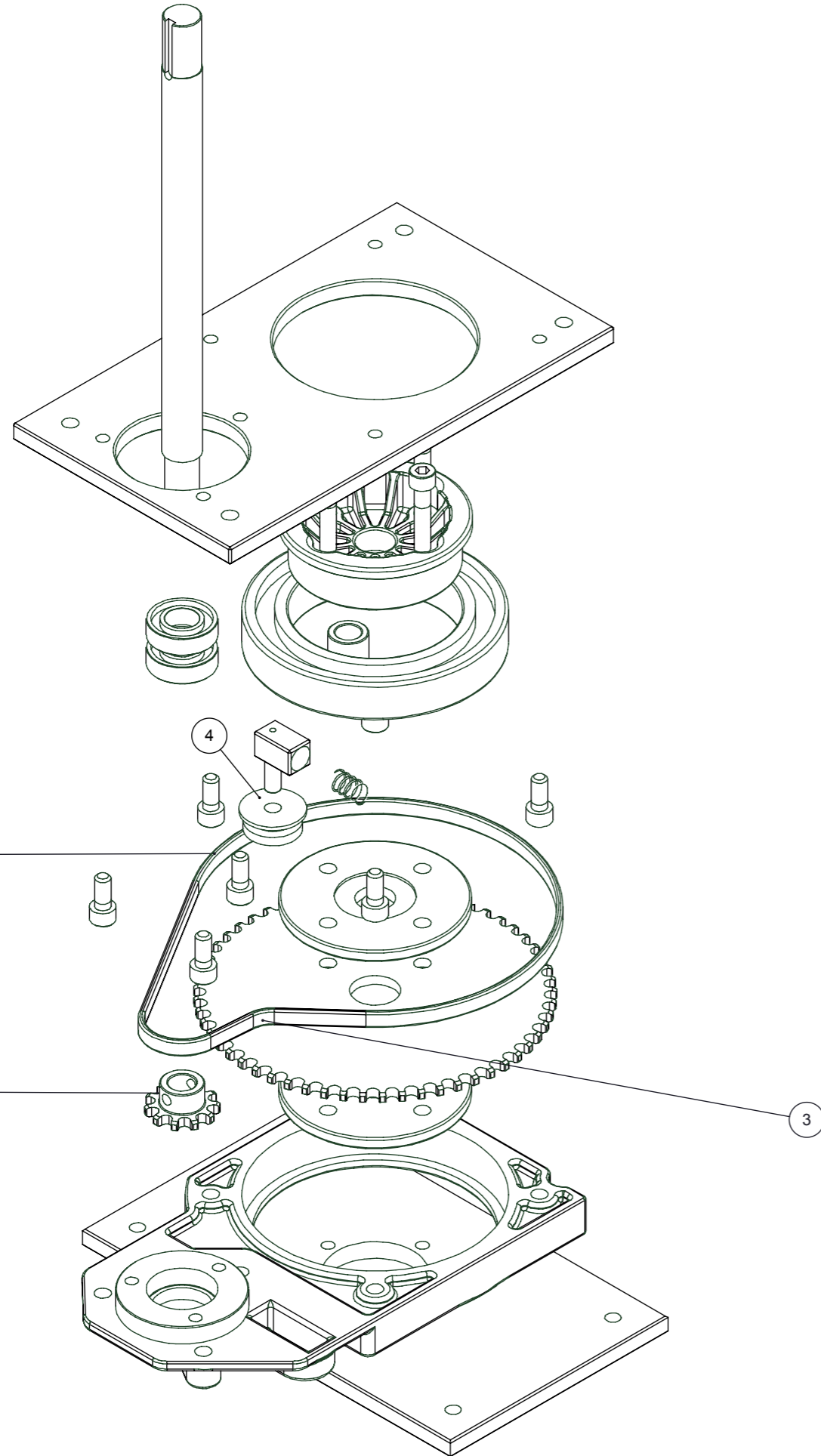

Numatic International Spare Parts

Model No: TTV678 & TRO650 MOTOR WHEEL GEARBOX ASSEMBLY EXPLODED DRAWING (EXP-1033)

POS:	ITEM NO:	DESCRIPTION:	COMMENTS:
1	208151	PINION	
2	208152	STEERING CHAIN	
3	208153	STEERING CHAIN MASTER LINK	
4	901617	WHEEL TENSIONER	AVAILABLE SEPERATELY

Numatic International Spare Parts

Model No: TTV678 & TRO650 Motor Wheel & Brake Assembly

234604
DRAWING: EXP-1032 ISS:A03
28/03/2014

NB: FOR WIRING SEE DRAWING: WD-0359, DRW-15631, DRW-13416, DRW-14741

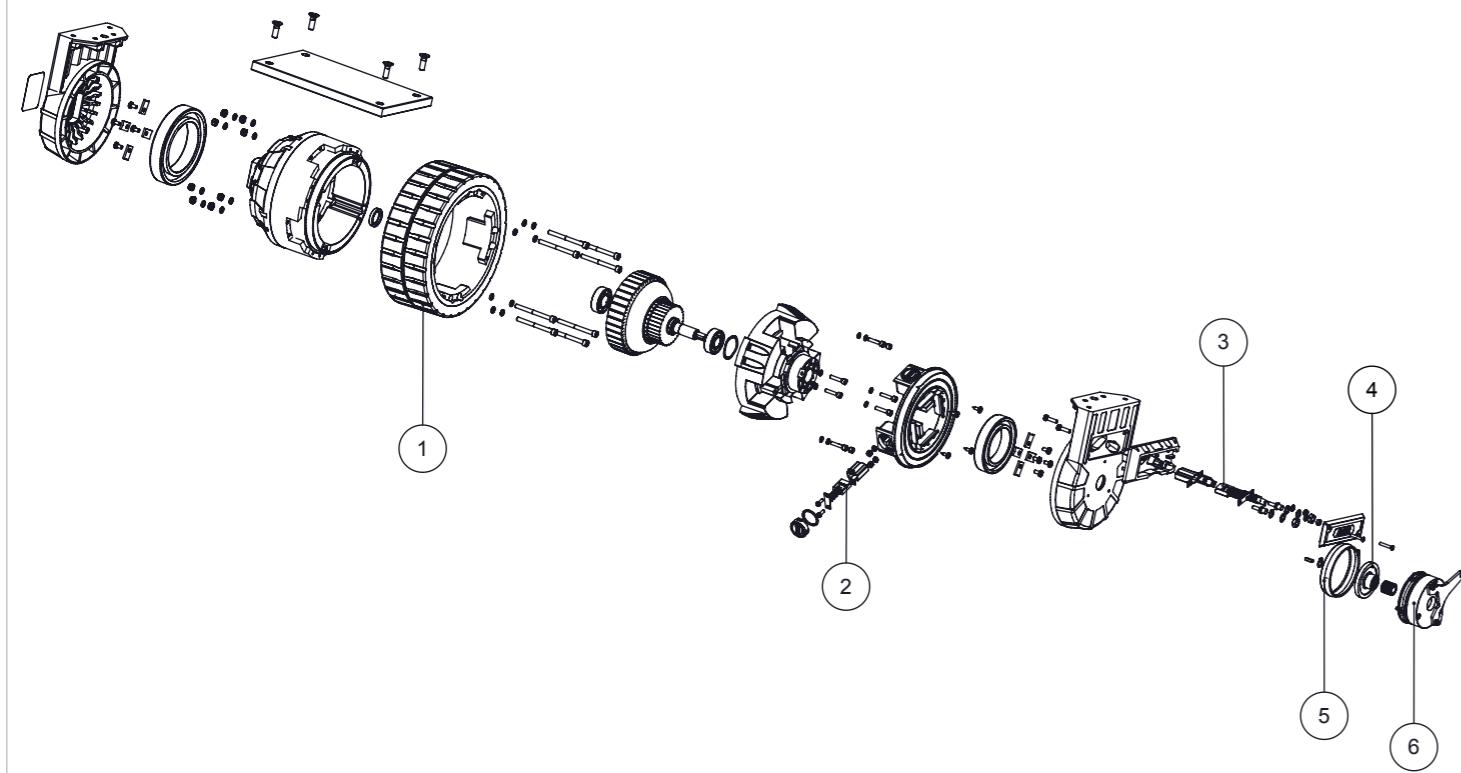

Numatic International Spare Parts

Model No: TTV678 & TRO650 Motor Wheel & Brake Assembly

POS:	ITEM NO:	DESCRIPTION:	COMMENTS:
1	208145	WHEEL	
2	208146	ARMATURE BRUSH	
3	208147	MOTOR BRUSH	
4	208148	FRICTION DISC	
5	208149	RUBBER GASKET	
6	321506	MODIFIED ELECTRONICALLY RELEASED BRAKE C/W PINION & SCREWS	

Numatic International Spare Parts

Model No: 850 TWINTEC ALUMINIUM FLOOR TOOL (38MM HOSE)

Internal Code: 599443 900481 900481 900481
 DRAWING: DRW-18079 ISS:A06
 PRO 27/03/2018

NB: FOR WIRING SEE DRAWING: N/A

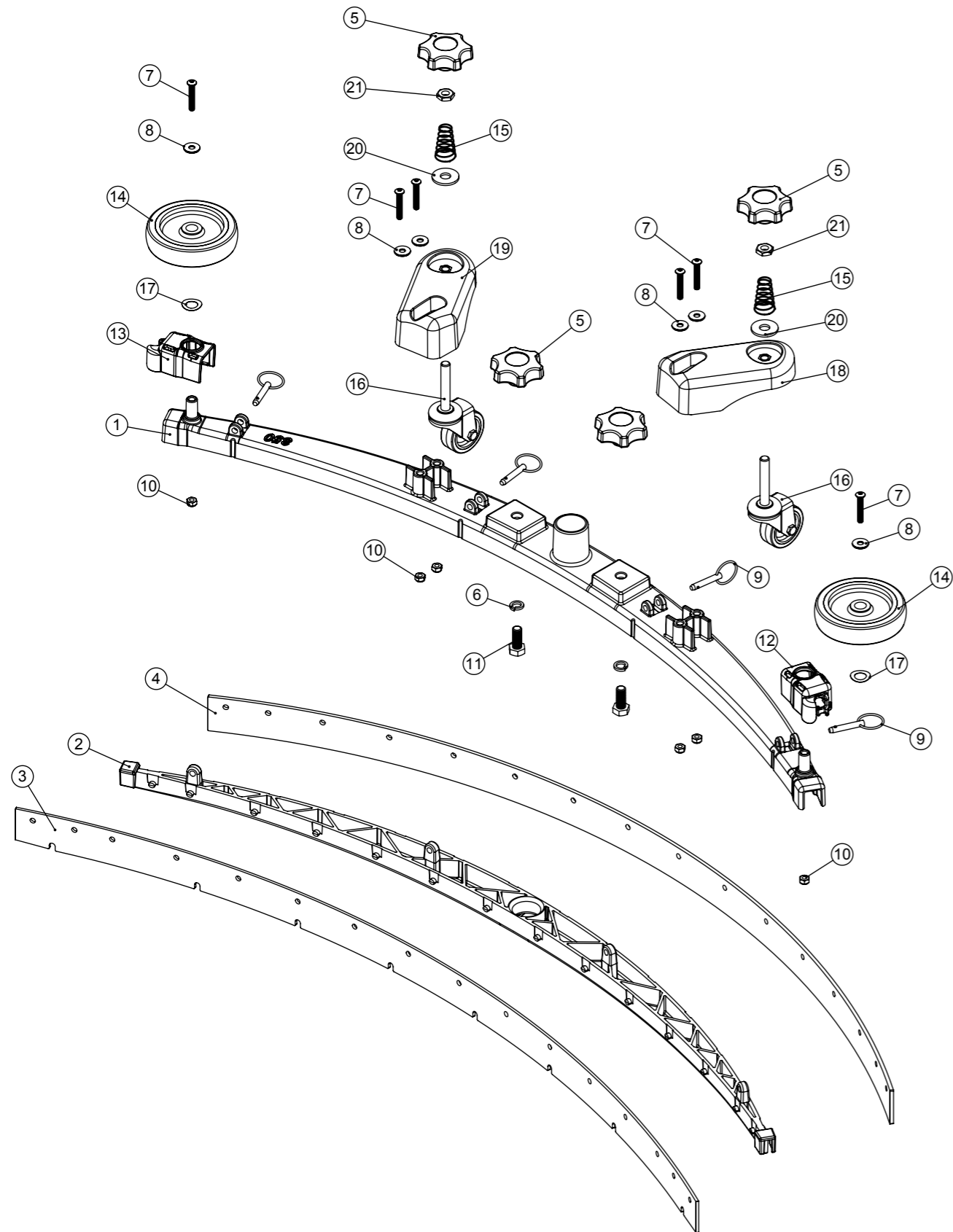

Numatic International Spare Parts

Model No: 850 TWINTEC ALUMINIUM FLOOR TOOL (38MM HOSE)

ITEM:	PART No:	DESCRIPTION	QTY.
1	208197	(850MM SCRUB WIDTH) ALUMINIUM SQUEEGEE CASTING (38MM HOSE FITTING)	1
2	229988	(850MM SCRUB WIDTH) BLADE HOLDER MOULDING (SLOPING PROFILE) (32MM & 38MM HOSE FITTING)	1
3	SEE TABLE	(850MM SCRUB WIDTH) REPLACEMENT (3.2MM / 40 SHORE A) FRONT MONOLAYER SERILOR POLY/BLADE (1085MM LONG)	1
4	SEE TABLE	850MM SCRUB WIDTH REPLACEMENT REAR BLADE (1117MM LONG)	1
5	903281	M10 LOBE KNOB (RED)	4
6	219899	M10 SINGLE COIL STAINLESS STEEL WASHER	2
7	219933	M6 X 35MM SOCKET BUTTON HEAD BOLT STAINLESS STEEL	6
8	219647	M6 FORM G STAINLESS STEEL WASHER	6
9	206953	DETENT PINS	4
10	219642	M6 STAINLESS STEEL NYLON INSERT NUT	6
11	219909	M10 X 25MM LONG HEXAGONAL STAINLESS STEEL SCREW	2
12	237322	RIGHT HAND FLOOR TOOL CLIP MOULDING	1
13	237323	LEFT HAND FLOOR TOOL CLIP MOULDING	1
14	208796	4 INCH WHEEL	2
15	229175	CONICAL SPRING	2
16	907759	50MM DIAMETER GREY TPR TYRED SWIVEL CASTOR C/W M10 X 60 SWAGED STEM.	2
17	219891	13MM WAVEY WASHER	2
18	906860	ADJUSTABLE FLOOR TOOL CASTOR PLASTIC PLATE LEFT	1
19	906859	ADJUSTABLE FLOOR TOOL CASTOR PLASTIC PLATE RIGHT	1
20	291124	M10 PENNY WASHER STAINLESS STEEL	2
21	219951	A4 (STAINLESS STEEL) M10 HEX LOCK NUT (HALF NUT)	2

BLADE	FRONT	REAR
POLYURETHANE 43 SHORE A	206949	206950
POLYURETHANE 50 SHORE A	208193	208195
LINATEX NATURAL RUBBER 40 SHORE A	208194	208196
SERILOR®CLEAN POLYURETHANE FRONT: 40 SHORE A / REAR: 35-45-35 SHORE A	208969	208972

WIRING DIAGRAM

COMP. No
123413

DRG. No
DRW-14741

WIRING DIAGRAM.TWINTC.2S.CL.NSF.NSF.TD.PLG

ISSUE	REVISION	DRAWN APPD.	DATE
A19	208566 REVISION A17 REF PRJ000174	AM MC	09/07/19

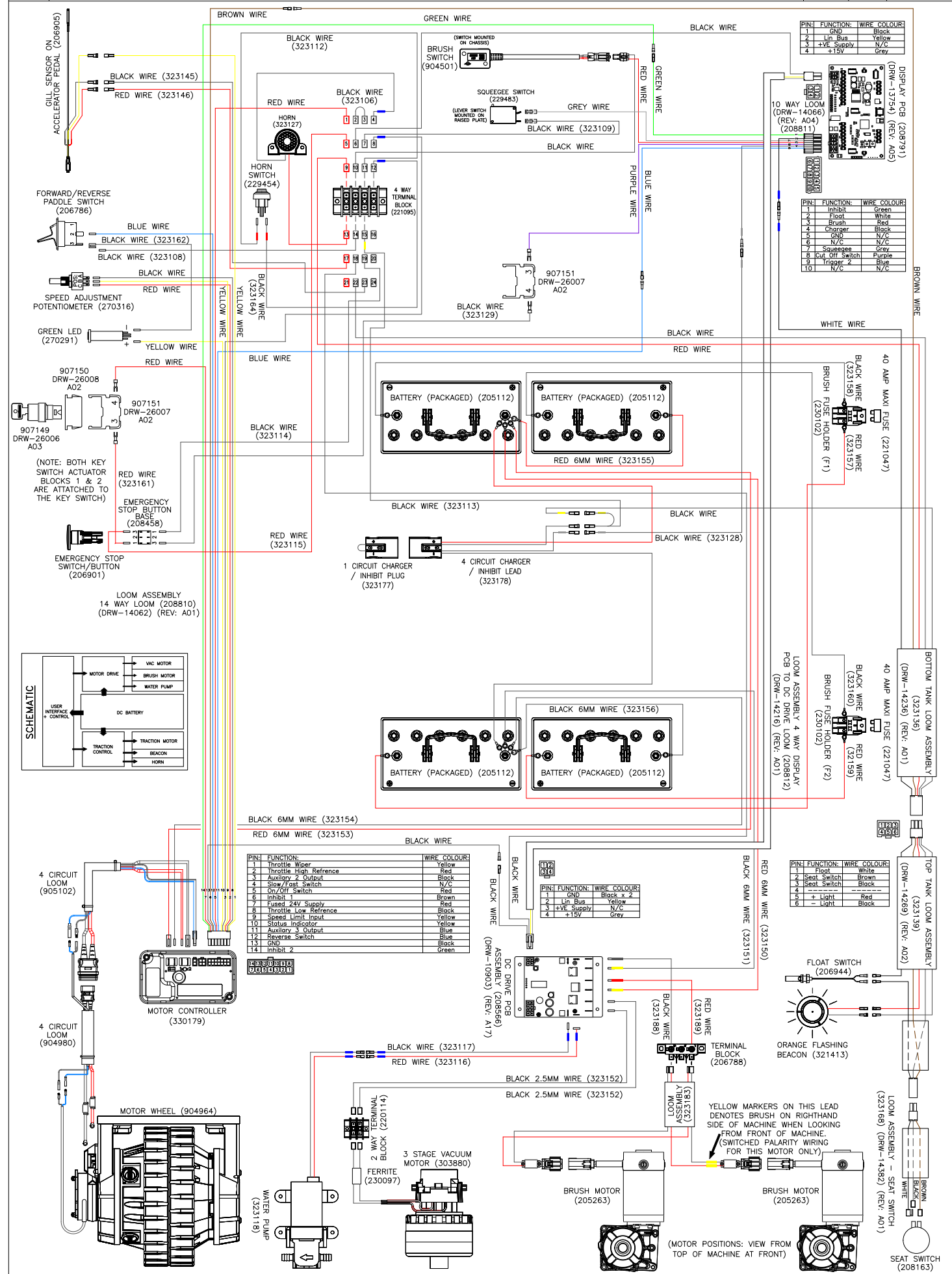

WIRING DIAGRAM

COMP. No
123413

DRG. No
DRW-14741

WIRING DIAGRAM.TWINTec.2S.CL.NSF.NSF.TD.PLG

ISSUE	REVISION	DRAWN	APPD.	DATE
A19	208566 REVISION A17 REF PRJ000174	AM	MC	09/07/19

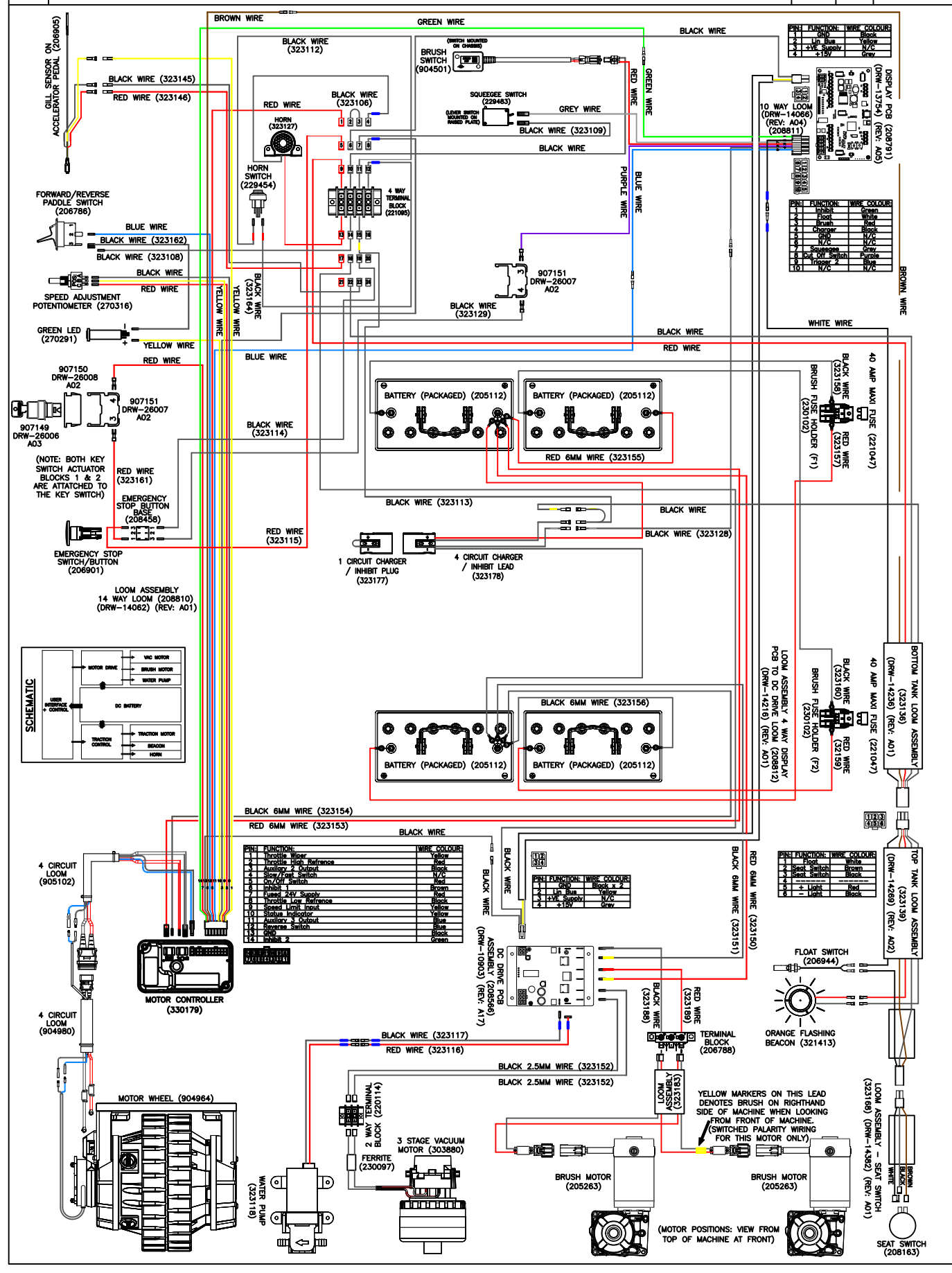

WIRING DIAGRAM

COMP. No
123407

DRG. No
DRW-13416

WIRING DIAGRAM.TWINTEC.1S.3WCR.230.56.TD.PLG

ISSUE	REVISION	DRAWN	APPD.	DATE
A28	208566 PCB UPDATED REF PROJ-1967. EMERGENCY STOP ITEM NUMBER CORRECTED TO 206901	AM	MC	06/09/2018

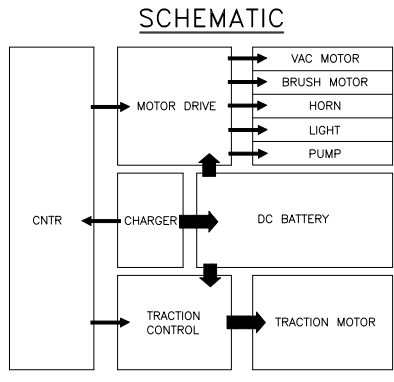
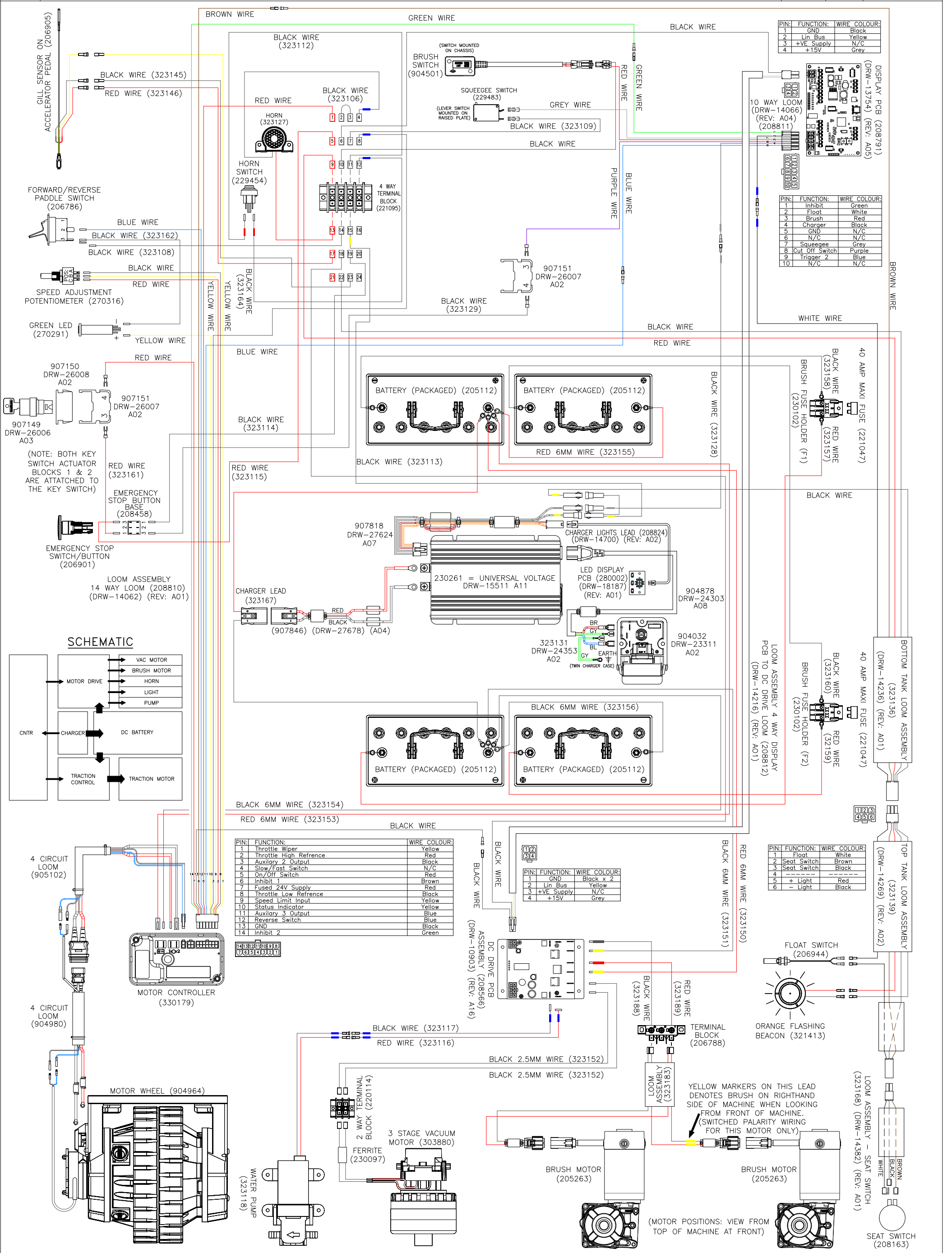

PIN:	FUNCTION:	WIRE COLOUR:
1	Throttle Wiper	Yellow
2	Throttle High Reference	Red
3	Auxiliary 2 Output	Black
4	Slow/Fast Switch	N/C
5	On/Off Switch	Red
6	Inhibit 1	Brown
7	Fused 24V Supply	Red
8	Throttle Low Reference	Black
9	Speed Limit Input	Yellow
10	Status Indicator	Yellow
11	Auxiliary 3 Output	Blue
12	Reverse Switch	Blue
13	GND	Black
14	Inhibit 2	Green

PIN:	FUNCTION:	WIRE COLOUR:
1	Inhibit	Green
2	Float	White
3	Brush	Red
4	Charger	Black
5	GND	N/C
6	N/C	N/C
7	Squeegie	Grey
8	Cut Off Switch	Purple
9	Trigger 2	Blue
10	N/C	N/C

PIN:	FUNCTION:	WIRE COLOUR:
1	GND	Black x 2
2	Lin Bus	Yellow
3	+VE Supply	N/C
4	+15V	Grey

PIN:	FUNCTION:	WIRE COLOUR:
1	Float Switch	Brown
2	Seat Switch	Black
3	Seat Switch	Black
4	+ Light	Red
6	- Light	Black

YELLOW MARKERS ON THIS LEAD DENOTES BRUSH ON RIGHTHAND SIDE OF MACHINE WHEN LOOKING FROM FRONT OF MACHINE. (SWITCHED PALARITY WIRING FOR THIS MOTOR ONLY)

(MOTOR POSITIONS: VIEW FROM TOP OF MACHINE AT FRONT)

WIRING DIAGRAM

COMP. No
123417

DRG. No
DRW-15631

WIRING DIAGRAM.TWINTEC.2S.CL.NSF.NSF.TD.PLG

ISSUE
A17

REVISION

HORN 321407 NOW REPLACED WITH DC BUZZER 915683

DRAWN
AM

APPD.
MB

DATE
19/08/2022

